

***Pioneer***

**ELITE**

**AUDIO/VIDEO  
MULTI-CHANNEL RECEIVER**

**VSX-33TX**

**Operating Instructions**

Thank you for buying this Pioneer product. Please read through these operating instructions so you will know how to operate your model properly. After you have finished reading the instructions, put them away in a safe place for future reference.

## [For U.S. model] IMPORTANT NOTICE

The serial number for this equipment is located on the rear panel. Please write this serial number on your enclosed warranty card and keep it in a secure area. This is for your security.

**WARNING: TO PREVENT FIRE OR SHOCK HAZARD, DO NOT EXPOSE THIS APPLIANCE TO RAIN OR MOISTURE.**

THE STANDBY/ON BUTTON IS SECONDARY CONNECTED AND THEREFORE DOES NOT SEPARATE THE UNIT FROM MAINS POWER IN STANDBY POSITION.

## IMPORTANT



The lightning flash with arrowhead symbol, within an equilateral triangle, is intended to alert the user to the presence of uninsulated "dangerous voltage" within the product's enclosure that may be of sufficient magnitude to constitute a risk of electric shock to persons.

### CAUTION

RISK OF ELECTRIC SHOCK  
DO NOT OPEN

CAUTION: TO PREVENT THE RISK OF ELECTRIC SHOCK, DO NOT REMOVE COVER (OR BACK). NO USER-SERVICEABLE PARTS INSIDE. REFER SERVICING TO QUALIFIED SERVICE PERSONNEL.



The exclamation point within an equilateral triangle is intended to alert the user to the presence of important operating and maintenance (servicing) instructions in the literature accompanying the appliance.

**NOTE:** This equipment has been tested and found to comply with the limits for a Class B digital device, pursuant to Part 15 of the FCC Rules. These limits are designed to provide reasonable protection against harmful interference in a residential installation. This equipment generates, uses, and can radiate radio frequency energy and, if not installed and used in accordance with the instructions, may cause harmful interference to radio communications. However, there is no guarantee that interference will not occur in a particular installation. If this equipment does cause harmful interference to radio or television reception, which can be determined by turning the equipment off and on, the user is encouraged to try to correct the interference by one or more of the following measures:

- Reorient or relocate the receiving antenna.
- Increase the separation between the equipment and receiver.
- Connect the equipment into an outlet on a circuit different from that to which the receiver is connected.
- Consult the dealer or an experienced radio/TV technician for help.

### Information to User

Alteration or modifications carried out without appropriate authorization may invalidate the user's right to operate the equipment.

#### [For Canadian model]

This Class B digital apparatus complies with Canadian ICES-003.

#### [Pour le modèle Canadien]

Cet appareil numérique de la classe B est conforme à la norme NMB-003 du Canada.

## [For Canadian model]

**CAUTION: TO PREVENT ELECTRIC SHOCK DO NOT USE THIS (POLARIZED) PLUG WITH AN EXTENSION CORD, RECEPTACLE OR OTHER OUTLET UNLESS THE BLADES CAN BE FULLY INSERTED TO PREVENT BLADE EXPOSURE.**

**ATTENTION: POUR PREVENIR LES CHOCs ELECTRIQUES NE PAS UTILISER CETTE FICHE POLARISEE AVEC UN PROLONGATEUR, UNE PRISE DE COURANT OU UNE AUTRE SORTIE DE COURANT, SAUF SI LES LAMES PEUVENT ETRE INSERES A FOND SANS EN LAISSER AUCUNE PARTIE A DECOUVERT.**

**ATTENTION: AFIN DE PREVENIR TOUS RISQUES DE CHOC ELECTRIQUE OU DE DEBUT D'ENCENDIE, NE PAS EXPOSER CET APPAREIL A L'HUMIDITE OU A LA PLUIE.**

LE BOUTON STANDBY/ON EST RACCORDE SECONDAIREMENT ET PAR CONSEQUENT NE SEPARA PAS L'APPAREIL DE L'ALIMENTATION SECTEUR SUR LA POSITION D'ATTENTE.

[For U.S. model]



As an ENERGY STAR® Partner, Pioneer Corporation has determined that this product meets the ENERGY STAR® guidelines for energy efficiency.

K001 En

# IMPORTANT SAFETY INSTRUCTIONS

**READ INSTRUCTIONS** — All the safety and operating instructions should be read before the product is operated.

**RETAIN INSTRUCTIONS** — The safety and operating instructions should be retained for future reference.

**HEED WARNINGS** — All warnings on the product and in the operating instructions should be adhered to.

**FOLLOW INSTRUCTIONS** — All operating and use instructions should be followed.

**CLEANING** — Unplug this product from the wall outlet before cleaning. The product should be cleaned only with a polishing cloth or a soft dry cloth. Never clean with furniture wax, benzene, insecticides or other volatile liquids since they may corrode the cabinet.

**ATTACHMENTS** — Do not use attachments not recommended by the product manufacturer as they may cause hazards.

**WATER AND MOISTURE** — Do not use this product near water — for example, near a bathtub, wash bowl, kitchen sink, or laundry tub; in a wet basement; or near a swimming pool; and the like.

**ACCESSORIES** — Do not place this product on an unstable cart, stand, tripod, bracket, or table. The product may fall, causing serious injury to a child or adult, and serious damage to the product. Use only with a cart, stand, tripod, bracket, or table recommended by the manufacturer, or sold with the product. Any mounting of the product should follow the manufacturer's instructions, and should use a mounting accessory recommended by the manufacturer.

**CART** — A product and cart combination should be moved with care. Quick stops, excessive force, and uneven surfaces may cause the product and cart combination to overturn.



**VENTILATION** — Slots and openings in the cabinet are provided for ventilation and to ensure reliable operation of the product and to protect it from overheating, and these openings must not be blocked or covered. The openings should never be blocked by placing the product on a bed, sofa, rug, or other similar surface. This product should not be placed in a built-in installation such as a bookcase or rack unless proper ventilation is provided or the manufacturer's instructions have been adhered to.

**POWER SOURCES** — This product should be operated only from the type of power source indicated on the marking label. If you are not sure of the type of power supply to your home, consult your product dealer or local power company.

**LOCATION** — The appliance should be installed in a stable location.

**NONUSE PERIODS** — The power cord of the appliance should be unplugged from the outlet when left un-used for a long period of time.

## GROUNDING OR POLARIZATION

- If this product is equipped with a polarized alternating current line plug (a plug having one blade wider than the other), it will fit into the outlet only one way. This is a safety feature. If you are unable to insert the plug fully into the outlet, try reversing the plug. If the plug should still fail to fit, contact your electrician to replace your obsolete outlet. Do not defeat the safety purpose of the polarized plug.

- If this product is equipped with a three-wire grounding type plug, a plug having a third (grounding) pin, it will only fit into a grounding type power outlet. This is a safety feature. If you are unable to insert the plug into the outlet, contact your electrician to replace your obsolete outlet. Do not defeat the safety purpose of the grounding type plug.

**POWER-CORD PROTECTION** — Power-supply cords should be routed so that they are not likely to be walked on or pinched by items placed upon or against them, paying particular attention to cords at plugs, convenience receptacles, and the point where they exit from the product.

**OUTDOOR ANTENNA GROUNDING** — If an outside antenna or cable system is connected to the product, be sure the antenna or cable system is grounded so as to provide some protection against voltage surges and built-up static charges. Article 810 of the National Electrical Code, ANSI/NFPA 70, provides information with regard to proper grounding of the mast and supporting structure, grounding of the lead-in wire to an antenna discharge unit, size of grounding conductors, location of antenna-discharge unit, connection to grounding electrodes, and requirements for the grounding electrode. See Figure A.

**LIGHTNING** — For added protection for this product during a lightning storm, or when it is left unattended and unused for long periods of time, unplug it from the wall outlet and disconnect the antenna or cable system. This will prevent damage to the product due to lightning and power-line surges.

**POWER LINES** — An outside antenna system should not be located in the vicinity of overhead power lines or other electric light or power circuits, or where it can fall into such power lines or circuits. When installing an outside antenna system, extreme care should be taken to keep from touching such power lines or circuits as contact with them might be fatal.

**OVERLOADING** — Do not overload wall outlets, extension cords, or integral convenience receptacles as this can result in a risk of fire or electric shock.

**OBJECT AND LIQUID ENTRY** — Never push objects of any kind into this product through openings as they may touch dangerous voltage points or short-out parts that could result in a fire or electric shock. Never spill liquid of any kind on the product.

**SERVICING** — Do not attempt to service this product yourself as opening or removing covers may expose you to dangerous voltage or other hazards. Refer all servicing to qualified service personnel.

**DAMAGE REQUIRING SERVICE** — Unplug this product from the wall outlet and refer servicing to qualified service personnel under the following conditions:

- When the power-supply cord or plug is damaged.
- If liquid has been spilled, or objects have fallen into the product.
- If the product has been exposed to rain or water.
- If the product does not operate normally by following the operating instructions. Adjust only those controls that are covered by the operating instructions as an improper adjustment of other controls may result in damage and will often require extensive work by a qualified technician to restore the product to its normal operation.
- If the product has been dropped or damaged in any way.
- When the product exhibits a distinct change in performance — this indicates a need for service.

**REPLACEMENT PARTS** — When replacement parts are required, be sure the service technician has used replacement parts specified by the manufacturer or have the same characteristics as the original part. Unauthorized substitutions may result in fire, electric shock, or other hazards.

**SAFETY CHECK** — Upon completion of any service or repairs to this product, ask the service technician to perform safety checks to determine that the product is in proper operating condition.

**WALL OR CEILING MOUNTING** — The product should not be mounted to a wall or ceiling.

**HEAT** — The product should be situated away from heat sources such as radiators, heat registers, stoves, or other products (including amplifiers) that produce heat.

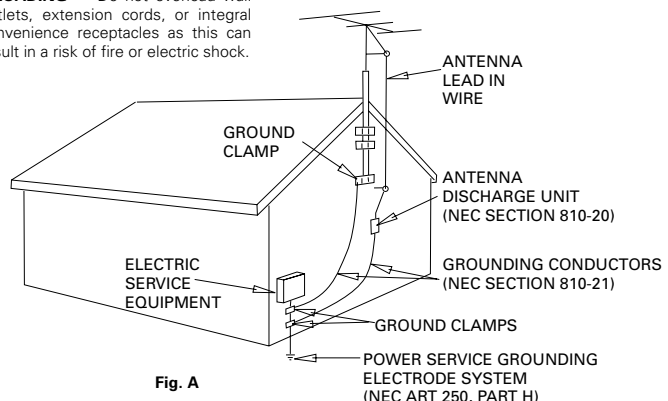

Fig. A

NEC — NATIONAL ELECTRICAL CODE

# Quick Start Guide

This is a quick guide to setting up your new receiver so you can get home theater surround sound. For more details on any of the information presented here check the main section of the manual.

**Before making or changing the connections, switch off the power and disconnect the power cord from the AC wall outlet.**

## 1 Hooking Up Your DVD Player & TV

In order to use Dolby Digital/DTS soundtracks which are at the heart of home theater you need to hook up your DVD player with digital audio connections. You can do this by either a coaxial or an optical connection, **you don't need to do both**. The quality of these two types of connections is the same but since some digital components only have one type of digital terminal you need to figure out which yours has and hook it up to the appropriate terminal on the receiver. In order to do this you will need the proper cable. For coaxial connections you can use a regular RCA stereo cord or the specially-made coaxial cords, they have the same type of plugs. For optical connections you will need a special optical cord which you can buy at your local stereo store. Also hook up the video connection of your DVD player, the analog audio (for recording the audio on DVDs, use regular RCA stereo cords), and your TV (it's easiest to use a regular composite RCA video cords) as shown below. We also recommend hooking up your all your digital components to analog audio jacks. For this you can use regular RCA stereo cords.

### Coaxial Digital Connection

If your DVD player has a coaxial terminal (not a PCM-only output) for the audio out hook it up using this terminal. Follow the diagram below. This is the best scenario, as you will be able to follow the default settings of this receiver and won't need to assign the digital inputs.

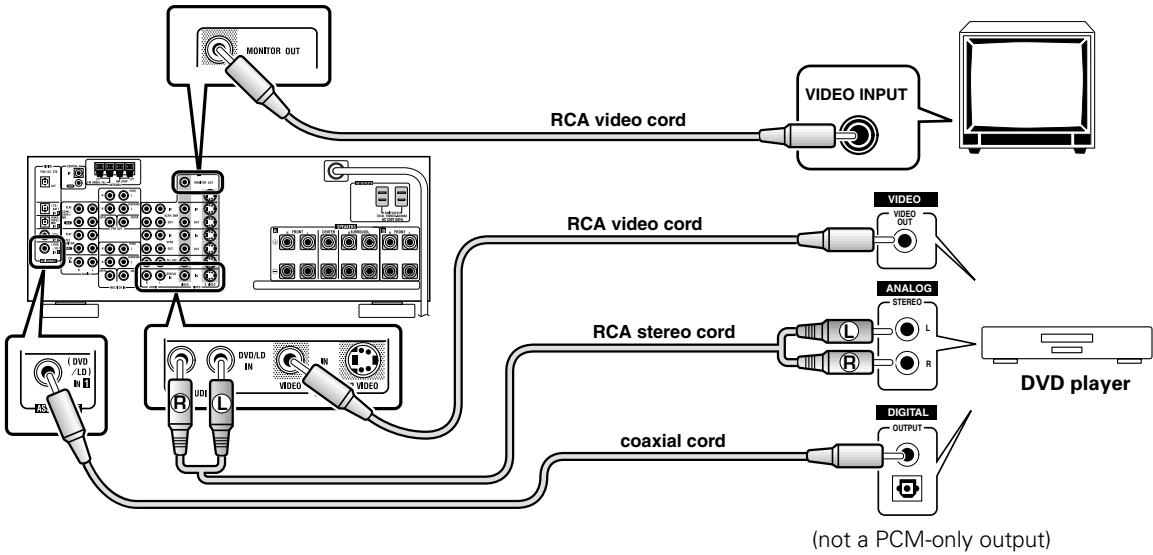

## Optical Digital Connection

If your DVD player has an optical terminal (not a PCM-only output) for the audio out you can hook it up using this following the diagram below. You will need to assign the digital input (tell the receiver which input you put your DVD digital audio into). See the page 6 for this.

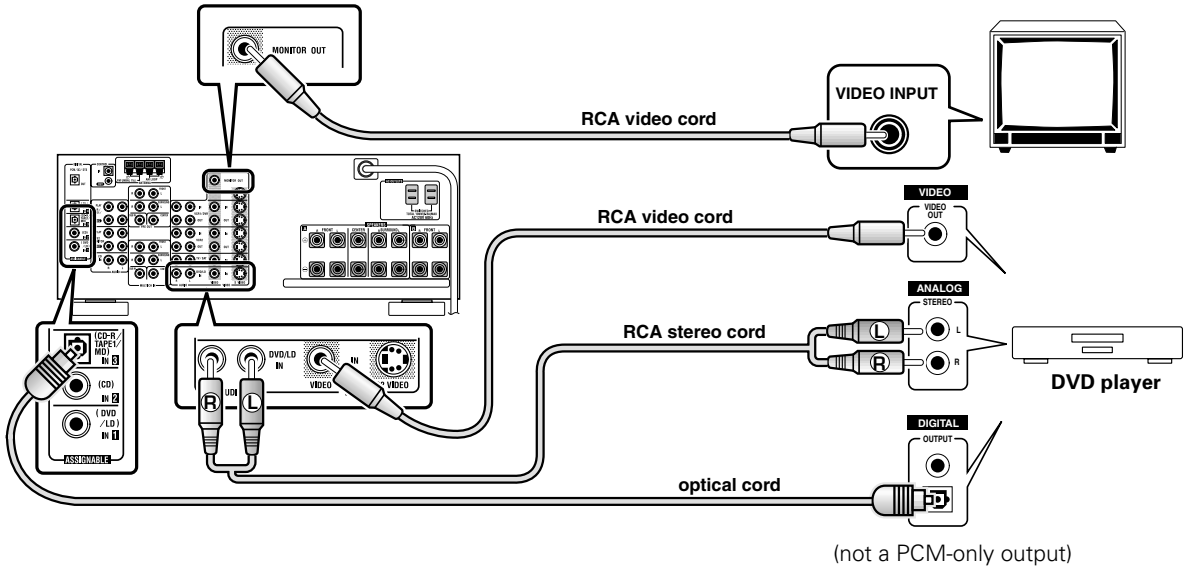

## 2 Speaker Connections

Home theater is designed to be setup with five speakers (front left & right; center; surround left & right) and a subwoofer but you can use this receiver with fewer speakers. Hook up the speakers you have to the **speaker A terminals** on the back of the receiver. If you only have two speakers hook them up as "FRONT." If you have three hook up the single speaker as "CENTER." Follow the diagram on p. 19 in order to hook up all your speakers. A center speaker is very important for watching films because the dialog comes from the center speaker in digital soundtracks. **If you do not have a CENTER speaker you must tell the receiver the CENTER channel is OFF or when you listen to digital soundtracks you won't hear any dialog.** Use the instructions on page 31-32 in order to do this.

Make sure you connect the speaker on the right to the right terminal and the speaker on the left to the left terminal. Also make sure the positive and negative (+/-) terminals on the amplifier match those on the speakers.

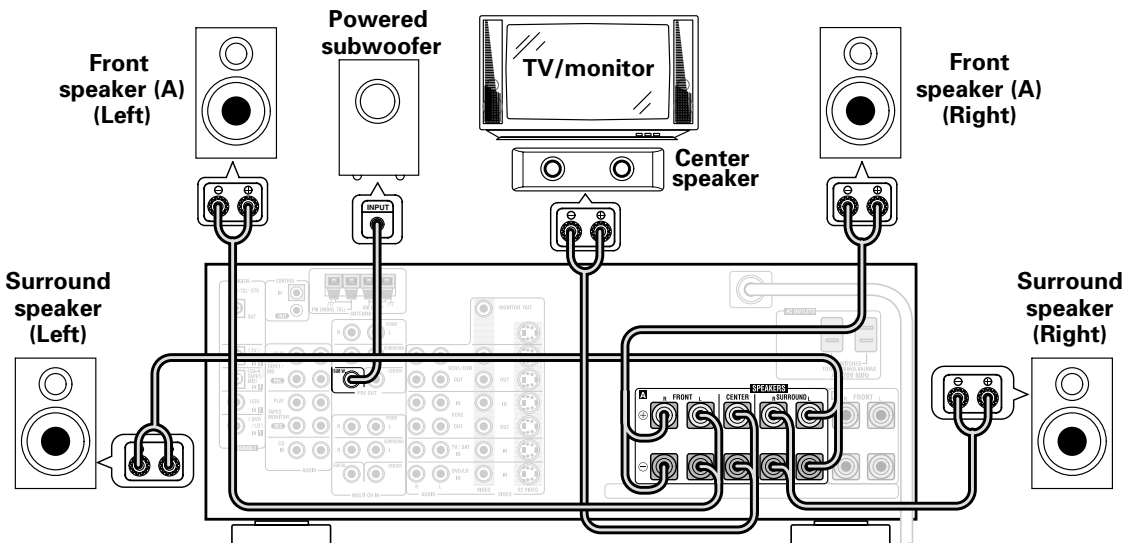

### 3 Setting up the Remote Control & Unit

- 1 Put the batteries in the remote control.
- 2 Plug the main unit into a AC wall outlet.
- 3 Press the  STANDBY/ON button on the receiver to put the receiver in ON mode.

### 4 Digital Input Assignment

This is only necessary if you hooked up your DVD to DIGITAL IN 3, as in the first diagram on p. 5.

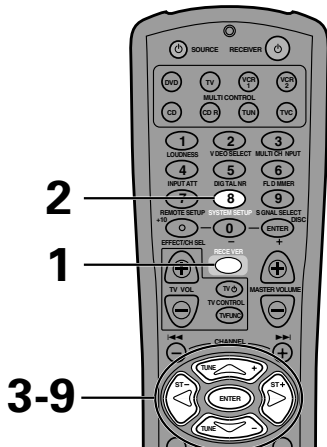

- 1 **Press the RECEIVER.**  
This switches the remote to the surround setup mode.
- 2 **Press the SYSTEM SETUP button.**  
You should see the following display on your receiver.



- You can escape from this screen at any time by pressing the SYSTEM SETUP button again. None of the settings you made will be entered in this case.
- If don't enter any settings the receiver will revert back to its prevoius state after three minutes.

- 3 **"Assgin Set" should be selected (if it isn't use the ▲/▼ buttons to select it). Press ENTER.**

You should see the following display on your receiver.

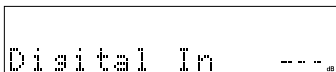

- 4 **"Digital In" should be selected (if it isn't use the ▲/▼ buttons to select it). Press ENTER.**

You should see the following display on your receiver.



- 5 **Choose the "Digital-3" with ▲/▼ buttons you hooked up your DVD player to. Press ENTER.**



- 6 **Choose the "DVD/LD"(if it isn't use the ▲/▼ buttons to select it). Press ENTER.**

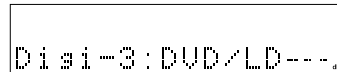

- 7 **Select "Dig-In End" with ▲/▼ buttons and press ENTER to return to the Dig-In Setup menu.**

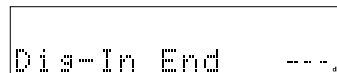

- 8 **Select "Assign End" with ▲/▼ buttons and press ENTER to return to the Assgin Setup menu.**

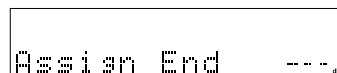

- 9 **Select "Setup End" with ▲/▼ buttons and press ENTER to return to the System Setup menu.**



## **5** Playing a DVD with Surround Sound

---

- 1 Turn on your TV, and the DVD player.**
- 2 Press the DVD button on the remote control.**  
You should see "DVD/LD" in the display on the receiver.
- 3 Press the STANDARD button for the basic surround sound setting.**
- 4 Play a DVD.**

## **6** For Better Surround Sound

---

- 1 Go through the entire "Initial Setup" procedures as outlined on pages 27– 38 of this instruction manual.**  
If you don't hook up any other components with digital audio or do so following the default settings of the receiver (see page 13) you won't have to assign any more digital inputs, but many other adjustments will improve the sound tremendously.
- 2 Experiment with the different sound settings offered with the DDD/DTS and DSP buttons.**  
For more information see pages 39-42.
- 3 As mentioned above you should go through the "SpeakerSetting" instructions on pages 31-32 to set up your speakers properly. If you don't do this you, at least, need to make sure the CENTER channel is turned off if you don't have a center speaker. Use the instructions on pages 31-32.**

# Features

## Multi Channel Stereophonic Concept

The VSX-33TX receiver is constructed with Pioneer's industry-leading multi channel stereophonic concept. This well-developed approach to receiver circuitry takes the high level base technology that, up until now, has been only used for stereo equipment and applies it to multi-channel audio-visual receivers. The result is that the product, in addition to being expertly built, and gives you optimal sound reproduction of DVDs, other multi channel sources and stereo sources as well. This receiver is designed capture to a true reproduction of the intentions of a filmmaker or music producer at the time they were mastering the soundtrack in the studio. It incorporates 5 independent 80 watt built in power amplifiers, with high-performance Hex power Direct Power MOS FET output transistors. This construction provides improved linearity and accurate representation of each channel for true high fidelity reproduction from even the most demanding Dolby Digital and DTS program sources. In addition, the amplifier uses Direct Construction to give the purest sound available. All these elements consolidated in one receiver afford the listener a new surround sound experience in his or her home.

## Universal Player Compatibility

This receiver incorporates the latest technology and is able to handle cutting edge audio formats, like DVD Audio, which are just hitting the market. Its high compatibility offers a variety of inputs to decode all types of sources at the highest possible quality. The receiver's multi channel in connections lets you hook up six discrete channels of audio. It also has multi channel direct inputs and the ability to decode the cutting edge formats.

## Decoding of Digital Source Film Formats

Built into this receiver is the latest in film sound format technology. This technology includes HOME THX CINEMA surround modes which employ special processing to allow you to enjoy movie soundtracks with the same level of power and realism you experience in well-designed movie theaters. This receiver has the ability to decode Dolby Digital, Dolby Pro Logic and DTS (Digital Theater Systems) sources, which are the standards of home theater today.

*Manufactured under license from Lucasfilm Ltd. U.S. patent numbers 5,043,970; 5,189,703; and/or 5,222,059. European patent number 0323830. Other U.S. and foreign patents pending. Lucasfilm and THX are registered trademarks of Lucasfilm Ltd.*

*"DTS" and "DTS Digital Surround" are trademarks of Digital Theater Systems, Inc. Manufactured under licence from Digital Theater Systems, Inc.*

*Manufactured under license from Dolby Laboratories. "Dolby", "Pro Logic", and double-D symbol are trademarks of Dolby Laboratories. Confidential unpublished works. © 1992 - 1997 Dolby Laboratories. All rights reserved.*

## Advanced Theater Modes & DSP Surround Modes

Advanced Theater modes enhance the sound of either film or music so a more dramatic effect can be achieved. The four modes are each designed to accentuate specific sound qualities, giving the listener a wide range of possibilities. DSP (Digital Signal Processing) surround modes give you the capability of transforming your living room into seven different sonic environments when listening to music.

## Midnight Mode, Digital Noise Reduction & 5 Channel Tone Control

The Midnight mode allows you to obtain excellent surround sound effects even when listening at low volumes, something that was previously impossible. Digital noise reduction filters out unwanted noise from recordings to give you a clearer sound and the 5 channel tone control allows you to adjust the treble and bass of each channel individually to suit your listening tastes.

## Remote Control of Other Components

The supplied remote control can be used to operate a variety of other components simply by recalling the appropriate preset codes or by using the learning function to teach the remote control new commands.

## The Energy-saving Design

This unit is designed to use less than 1 W of energy when the receiver is in standby mode.



# Table of Contents

<b>Quick Start Guide</b> .....	<b>4</b>	<b>Remote Control of Other Components</b> ..	<b>55</b>
<b>Before You Start</b> .....	<b>10</b>	Setting Up the Remote Control .....	55
Checking the Supplied Accessories .....	10	Programming a Different Component into a MULTI CONTROL button .....	58
How to Use This Manual .....	10	Checking Preset Codes .....	58
Preparing the Remote Control .....	10	Clearing One of the Remote Control Settings .....	59
Installing the Receiver .....	11	Clearing All the Remote Control Settings .....	59
Opening the Front Panel .....	11	CD/CD-R/MD/VCR/LD Player Controls .....	60
The PIONEER SR System: Operating other PIONEER components .....	11	Cassette Deck Controls .....	61
<b>Connecting Your Equipment</b> .....	<b>12</b>	DVD/DVR Player Controls .....	62
Audio Components .....	12	DTV Controls .....	63
Digital Connections .....	13	Cable TV/Sattelite TV/TV Controls .....	64
Example Connection for a DVD/LD or LD player ....	14	<b>Using Other Functions</b> .....	<b>65</b>
Video Components .....	15	Function Rename .....	65
TV/Satellite tuner Components .....	16	Recording from Audio Components .....	67
TV .....	17	Recording from Digital Audio Components .....	68
Multi Channel Input (External Decoder) .....	17	Recording from Video Components .....	68
Connecting the Radio Antennas .....	18	Direct Function .....	69
Speakers .....	19	Video Select .....	70
Placing Your Speakers .....	20	Changing the Display .....	70
Connecting Additional Amplifiers .....	21	<b>Techno Tidbits &amp; Problem-solving</b> ...	<b>71</b>
Plugging In .....	21	Dolby Digital .....	71
<b>Displays &amp; Controls</b> .....	<b>22</b>	DTS .....	71
Front Panel .....	22	THX .....	72
Remote Control .....	24	Preset Code List .....	73
Display .....	26	Troubleshooting .....	78
<b>Initial Setup</b> .....	<b>27</b>	Specifications .....	81
Setting Up for Surround Sound .....	27		
<b>Basic Playback</b> .....	<b>39</b>		
Learning about the Sound Modes .....	39		
Selecting a Sound Mode .....	41		
Playing Sources with			
Dolby Digital or DTS Sound .....	42		
Playing Stereo Sources .....	43		
Switching Analog and Digital Signal Input .....	44		
Reducing Noise During Playback .....	45		
Listening in Midnight Mode .....	46		
Listening the Loudness Mode .....	46		
Adjusting Bass and Treble .....	47		
MULTI CHANNEL IN Playback .....	48		
96 kHz 24 bit Performance .....	48		
Direct Playback .....	49		
Adjusting the Brightness of the Display .....	49		
DUAL MONO Setting .....	50		
<b>Using the Tuner</b> .....	<b>51</b>		
Automatic and Manual Tuning .....	51		
Direct Access Tuning .....	52		
Memorizing Frequently Used Stations .....	53		
Recalling Memorized Stations .....	54		

# Before You Start

## Checking the Supplied Accessories

Please check that you have received all of the following supplied accessories.



FM wire Antenna



AM loop Antenna



“AA” IEC LR6  
batteries x 2

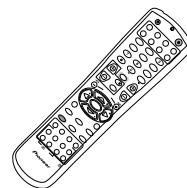

Remote Control Unit

• Operating Instructions

## How to Use This Manual

This manual is for the VSX-33TX Audio/Video Multi-Channel Receiver.

This manual is divided into three main sections which will tell you how to setup and use the unit :

### PREPARATION

First carry out the tasks below in this “Before You Start” section to prepare the remote control, then connect the receiver to your other components as described in “Connecting Your Equipment” (p.12). Take special care to connect your digital equipment like DVDs and LDs properly to be able to take advantage of the receiver’s surround sound systems (p.13-14). To learn about a specific button, control, or indicator, see “Displays & Controls” starting on p.22.

### SET UP

Performing the tasks in “Initial Setup” (from p.27) is essential to get proper surround sound.

### OPERATION

To play some music or soundtrack refer to “Basic Playback” on p.39. “Using the Tuner” (p.51) explains how to use the radio of this unit. Doing the operations in “Remote Control of Other Components” (p.55) is highly recommended so you can use this unit’s remote control for all your components. “Using Other Functions” (p.65) explain the other possibilities of the receiver.

“Techno Tidbits & Problem-solving” (p.71) provide detailed technical information and a troubleshooting guide.

The following marks and symbols are used throughout the manual:



Provides additional information, precautions, and advice.



Indicates a blinking button, indicator, or display.



Indicates a steadily lit button, indicator, or display.

## Preparing the Remote Control

### Loading the batteries

Load the batteries into the remote control as shown below. Please use alkaline batteries. When you notice a decrease in the operating range of the remote control, replace all batteries with new ones.

“AA” IEC LR6 batteries x 2

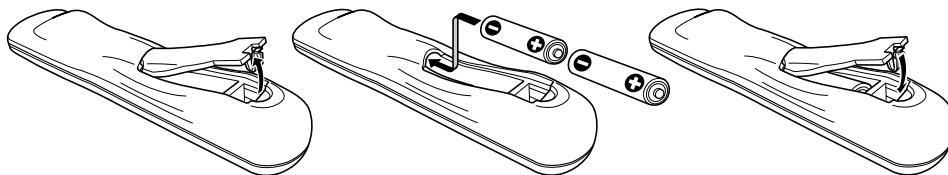

### CAUTION!

Incorrect use of batteries may result in such hazards as leakage and bursting. Observe the following precautions.

- Never use new and old batteries together.
- Insert the plus and minus sides of the batteries properly according to the marks in the battery case.
- Batteries with the same shape may have different voltages. Do not use different batteries together.
- When disposing of used batteries, please comply with governmental regulations or environmental public institution’s rules that apply in your country or area.

## Operating range of remote control unit

The area in which you can use the remote control to operate the VSX-33TX is fairly large. To use, point the remote control toward the remote sensor on the front panel of this unit while within the range shown in right.

Remote control may not function properly if:

- There are obstacles between the remote control and the remote sensor.
- Direct sunlight or fluorescent light is shining onto the remote sensor.
- The receiver located near a device emitting infrared rays.
- Operated simultaneously with another remote control which uses infrared rays.

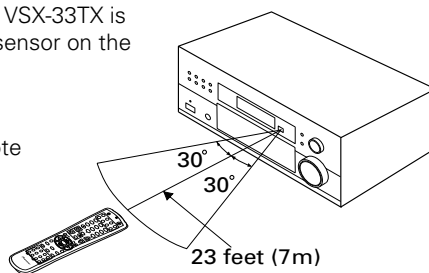

## Installing the Receiver

Please note:

- Do not place objects directly on top of this unit. This would prevent proper heat dispersal.
- When installing in a rack, shelf, etc., be sure to leave more than 8 inches of space above the receiver.

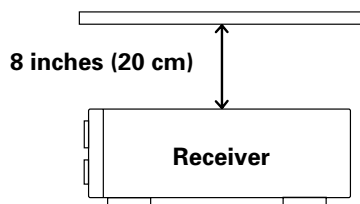

## Opening the Front Panel

To open the front panel push gently on the lower third of the panel with your finger.

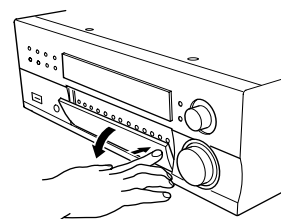

## The PIONEER SR System: Operating other PIONEER components

Connecting an optional control cord allows you to operate other PIONEER components simply by pointing the receiver's remote control at the remote sensor on the front panel of the receiver. The receiver then sends the remote control signals to the other devices via the CONTROL OUT terminal.

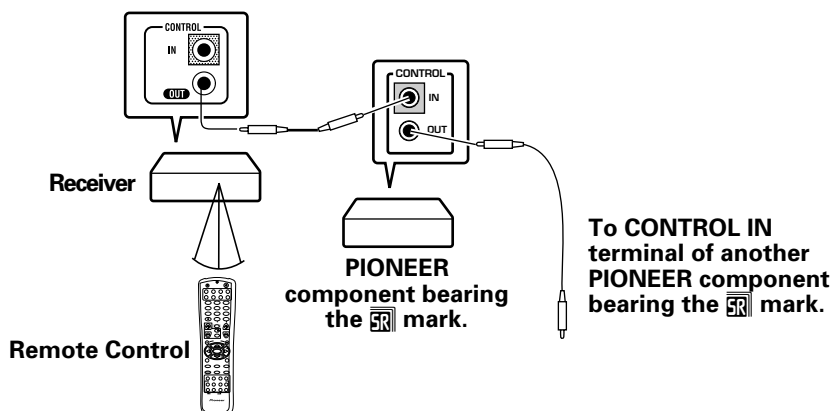

- You can also control PIONEER components (and those made by other manufacturers) by pointing the receiver's remote control directly at the respective component. This type of operation does not require control cords. All you have to do is recall the appropriate the stored settings (see p.58-59).
- If you use a remote control hooked up via the CONTROL IN jack with a control cord, you won't be able to use this unit's remote control.

# Connecting Your Equipment

## Audio Components

To begin set up connect your audio components to the jacks as shown below. These are all analog connections and your analog audio components (cassette deck) use these jacks. Remember that for components you want to record with you need to hook up four plugs (a set of stereo ins and a set of stereo outs), but for components that only play you only need to hook up one set of stereo plugs (two plugs). To use DTS or Dolby Digital surround sound features you must hook up your digital components to the digital inputs (see p.13). We also recommend hooking up your digital components to analog audio jacks. If you want to record to/from digital components (like a CD-R) to/from analog components you must hook up your digital equipment with these analog connections. See p.13 & 14 for more on digital connections.

Before making or changing the connections, switch off the power and disconnect the power cord from the AC wall outlet.

\*The arrows indicate the direction of the audio signal.

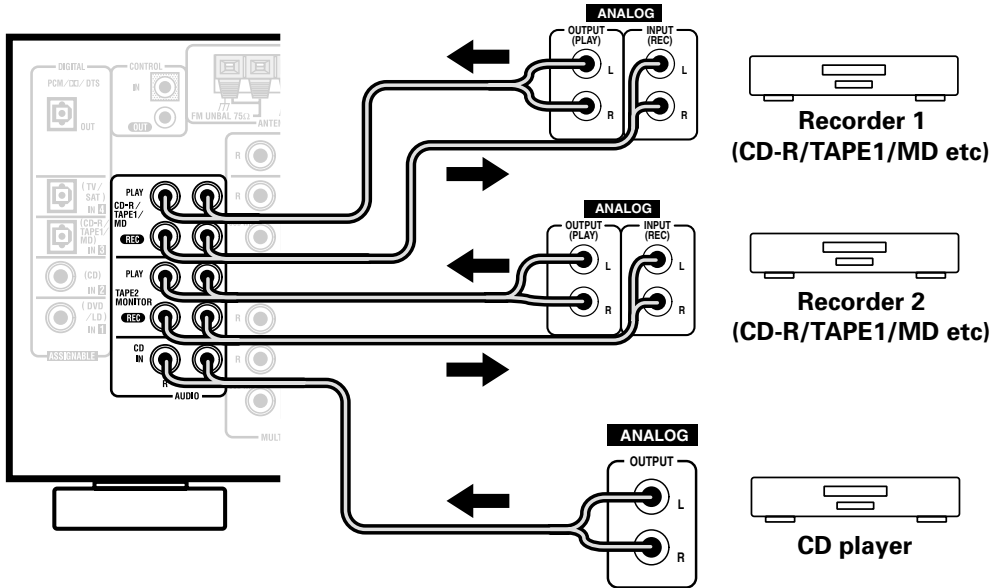

**■ Analog audio/video cords**  
 Use audio/video cords (not supplied) to make analog audio and video connections.

Connect red plugs to R (right) and white plugs to L (left).  
 Be sure to insert completely.

### Cassette deck placement

Depending on where the cassette deck is placed, noise may occur during playback of your cassette deck which is caused by leakage flux from the transformer in the receiver. If you experience noise, move the cassette deck farther away from the receiver.

**■ Coaxial cords/Optical cables**  
 Commercially available digital audio coaxial cords (standard video cords can also be used) or optical cables (not supplied) are used to connect digital components to this receiver.

When you use optical digital input or output terminals, pull off the caps and insert the plugs. Be sure to insert completely.

#### Coaxial cord (or standard video cord)

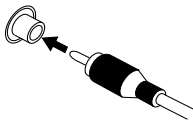

#### Optical cable

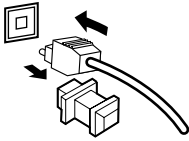

## Digital Connections

In order to use Dolby Digital/DTS soundtracks which are at the heart of home theater you need to make digital audio connections. You can do this by either a coaxial or an optical connection (you don't need to do both). The quality of these two types of connections is the same but since some digital components only have one type of digital terminal, it is a matter of matching like with like (for example, the coaxial out from the component to coaxial in on the receiver). The VSX-33TX has two coaxial and two optical inputs for a total of four digital inputs. For a DVD/LD player or LD player hook up see p.14. If possible hook up your digital equipment in accordance with this receiver's default settings, refer to the "Digital Input Assignment" on this page in order to do this. We also recommend hooking up your digital components to analog audio jacks in order to make recording from some digital sources which may be copy protected.

Connect your digital components as shown below.

There is one optical digital out jack (the CD recorder is connected to one in the diagram below). If you connect this to the optical input on a digital recorder (currently these include MD, DAT and CD-R) you can make direct digital recordings with this unit.

Before making or changing the connections, switch off the power and disconnect the power cord from the AC wall outlet.

\*The arrows indicate the direction of the audio signal.

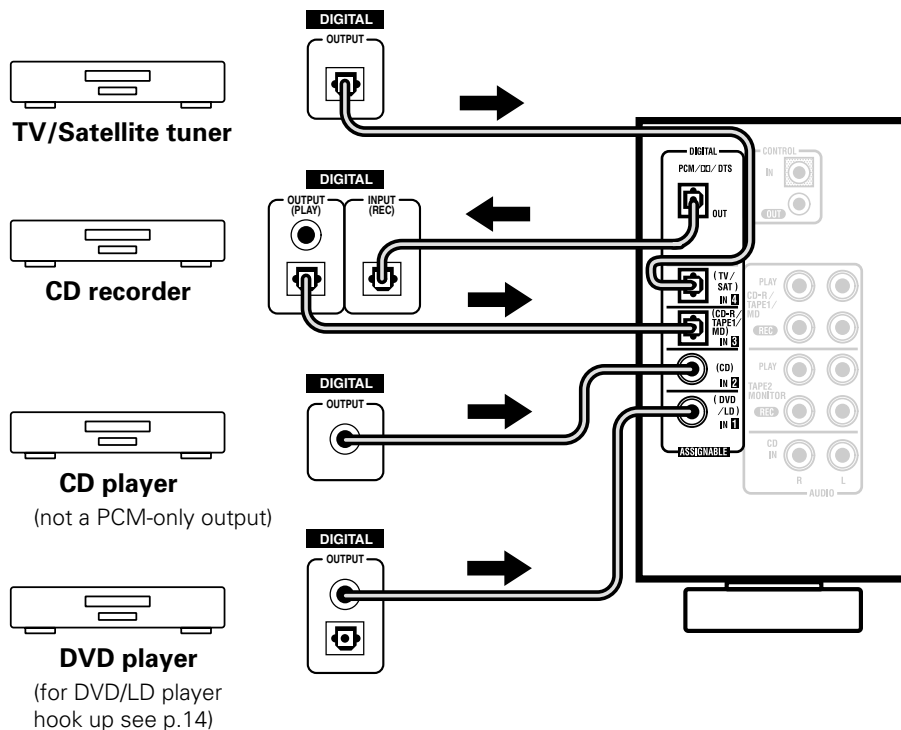

## Digital Input Assignment

Unlike analog connections, the jacks for digital connections are not dedicated to one type of component, they can be used freely. Thus you must tell the receiver what digital component is in which jack so your components will be in sync with the the names on the remote control buttons and the like. To avoid having to assign the digital inputs you can hook up your equipment in accordance with the receiver's default settings. The default settings are:

- DIGITAL IN 1: DVD/LD
- DIGITAL IN 2: CD
- DIGITAL IN 3: CD-R/TAPE1/MD
- DIGITAL IN 4: TV/SAT

You will notice that Digital IN 1, for example, is a coaxial jack. If your DVD/LD player only has an optical out jack on it then you won't be able to hook up your components in accordance with the VSX-33TX default setting. In this case you will need to assign the digital inputs. See Digital Input Select on p.29 in order to do this.

### Example Connection for a DVD/LD or LD player

Make sure you connect your DVD/LD or LD players using both a RF demodulator and either a coaxial or optical digital connections. To connect a DVD/LD player or LD player with it's **AC-3** RF output, a commercially available RF demodulator (RFD-1) is required. The RF demodulator changes the RF signal to a digital signal which is then processed by the VSX-33TX model through their digital input jacks. For more details, refer to the instruction manual supplied with the RFD-1. If your player has an **AC-3** RF output this will ensure you can use all LDs. We also recommend hooking up your digital components to analog audio jacks. Before making or changing the connections, switch off the power and disconnect the power cord from the AC wall outlet.

\*The arrows indicate the direction of the audio signal.

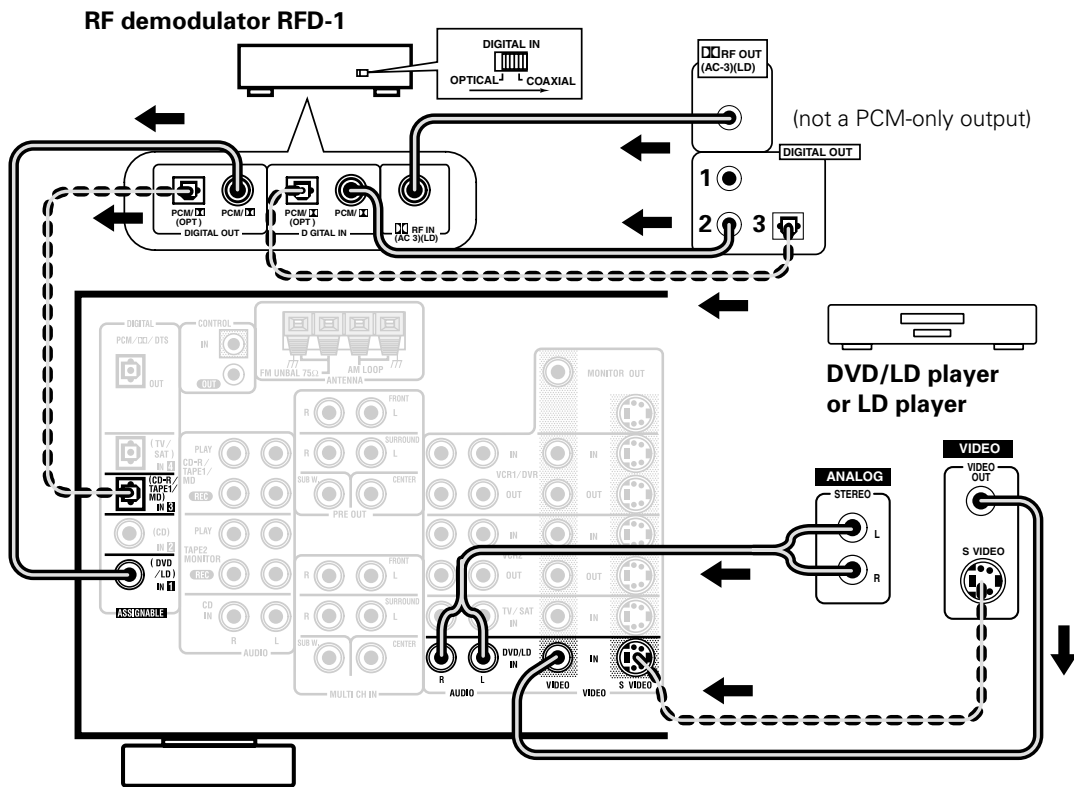

Be sure to make either a digital coaxial or digital optical connection (pictured as DIGITAL jack 1 or DIGITAL jack 3 in this diagram) as well, but you don't need to make both.

Also, be sure to assign the jacks to the proper component(s) with the Digital Input Select procedure (see p.29) if necessary. See the explanation on p.13 for details.

Make sure the RF demodulator digital in switch is set correctly (optical or coaxial depending on the connection).

## Video Components

Connect your video components to the jacks as shown below. Regarding a DVD there are two types of connections to make. Hook up your video signal with either S-video or composite video cords (the quality descends in this order) but remember, the video component you are watching and your TV must be hooked up with same type of video cord or you won't be able to see the picture. For the audio signal, in order to use Dolby Digital/DTS you must hook up a digital input. It is also a good idea to hook up your DVD components with analog audio connections as well, since some DVDs may not have a digital audio track. To cover all possible LaserDiscs a DVD/LD player or LD player requires an analog connection and two digital connections (a coaxial or optical and a specialized RF demodulator connection shown on 14 page). Before making or changing the connections, switch off the power and disconnect the DVD power cord from the AC wall outlet.

\*The arrows indicate the direction of the video signal.

### Connecting DVD players

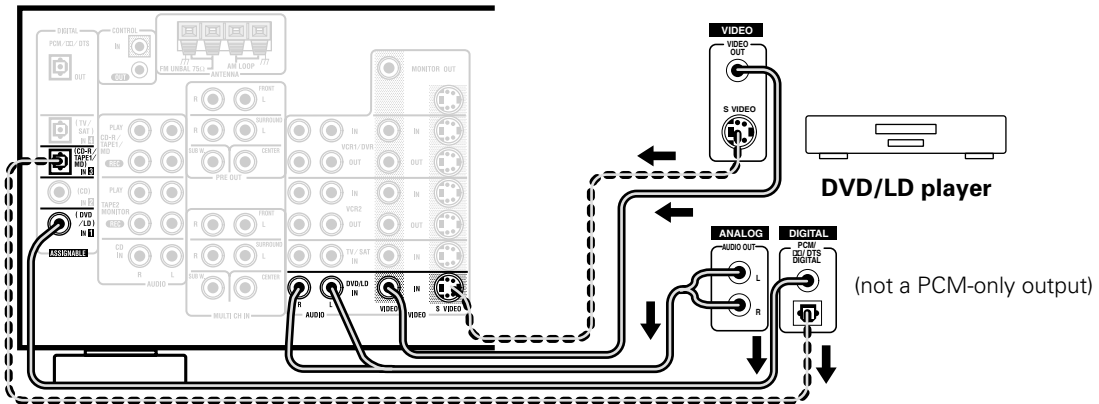

### Connecting VCRs or DVRs

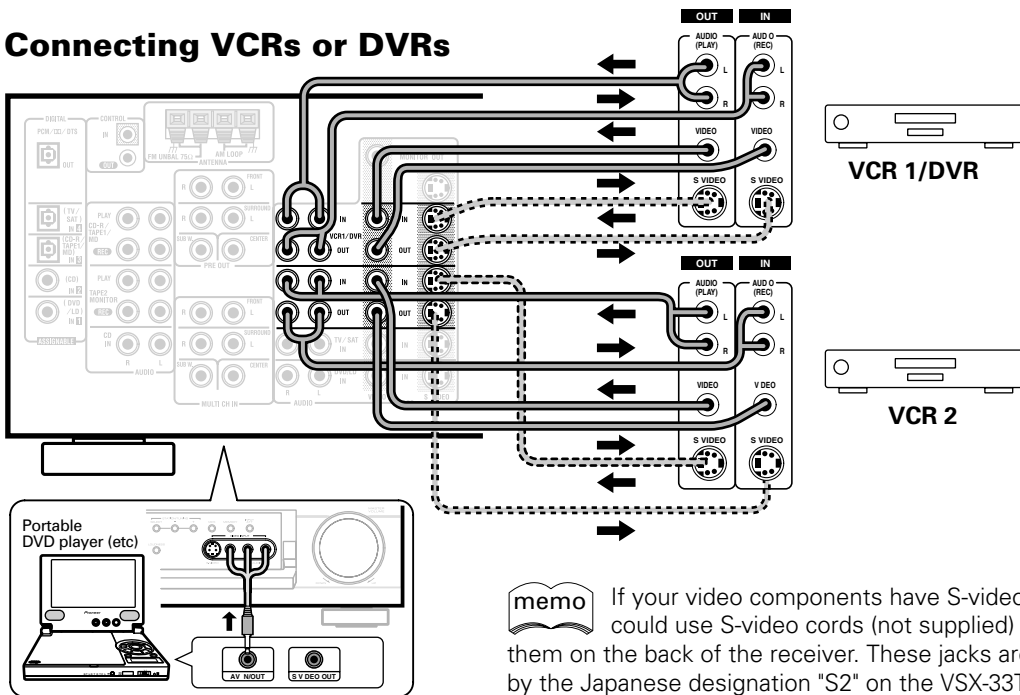

**memo** If your video components have S-video jacks, you could use S-video cords (not supplied) to connect them on the back of the receiver. These jacks are labeled by the Japanese designation "S2" on the VSX-33TX but they are simply S-video jacks.

However, if you use S-video cords for your video hook ups you must also hook up your TV with S-video connections. Conversely, if you use regular composite video cords for video hook ups, you should use them for your TV as well.

Front video connections are accessed via the front panel input selector as "VIDEO."

## TV/Satellite tuner Components

Connect your satellite TV components to the jacks as shown below. Hook up the video signal with either S-video, or composite video cords (the quality descends in this order) but remember, the video component you are watching and your TV must be hooked up with same type of video cord or you won't be able to see the picture. For the audio signal, in order to use digital soundtracks (sometimes broadcast over digital satellite TV) you must hook up a digital input. Use either a coaxial or optical cables, it doesn't matter which (you don't need to use use both). It's also a good idea to hook up your audio with analog cables (see below). This connection is called STEREO AUDIO OUT in the diagram.

Before making or changing the connections, switch off the power and disconnect the power cord from the AC wall outlet.

\*The arrows indicate the direction of the TV signal.

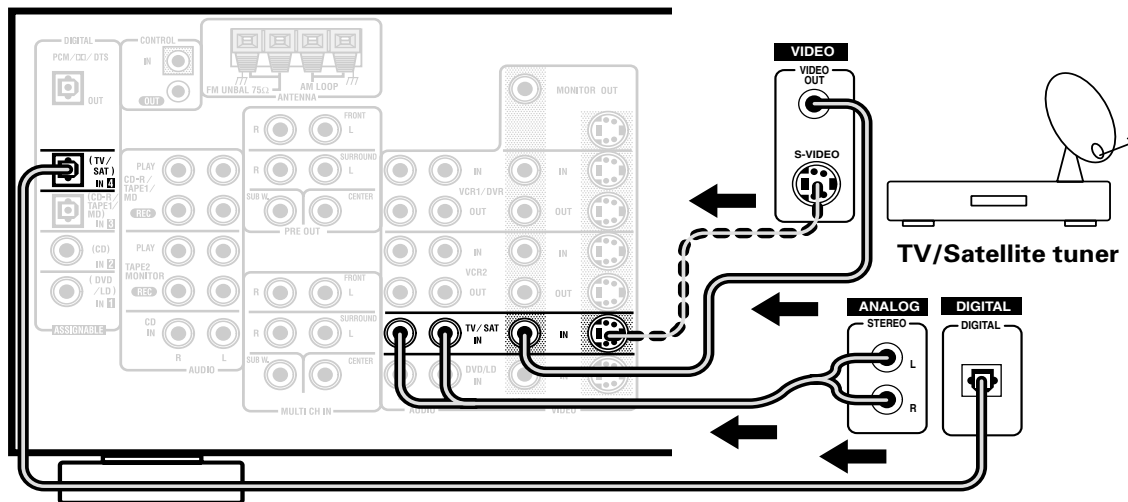



# TV

Connect your TV to the jacks as shown below. Hook up the signal with either S-video or composite video cords (the quality descends in this order) but remember, the video component you are watching and your TV must be hooked up with same type of video cord or you won't be able to see the picture. Before making or changing the connections, switch off the power and disconnect the power cord from the AC wall outlet.

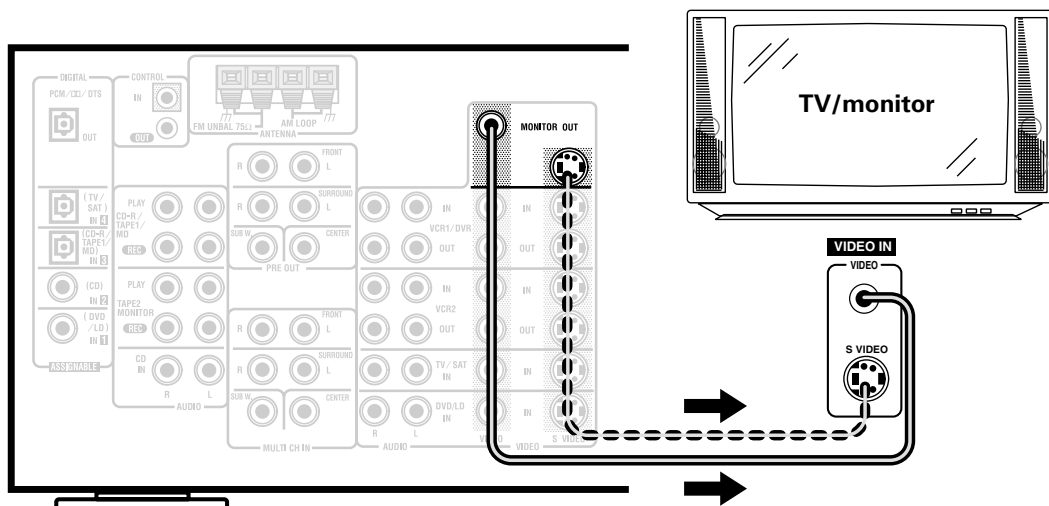

PREPARATION

## Multi Channel Input (External Decoder)

In some cases you may want to have you source material (DVD, etc) decoded externally. If you find you need a multi channel external decoder hook one up as shown below, but for most people this component is unnecessary (For more on this see p.48). Before making or changing the connections, switch off the power and disconnect the power cord from the AC wall outlet.

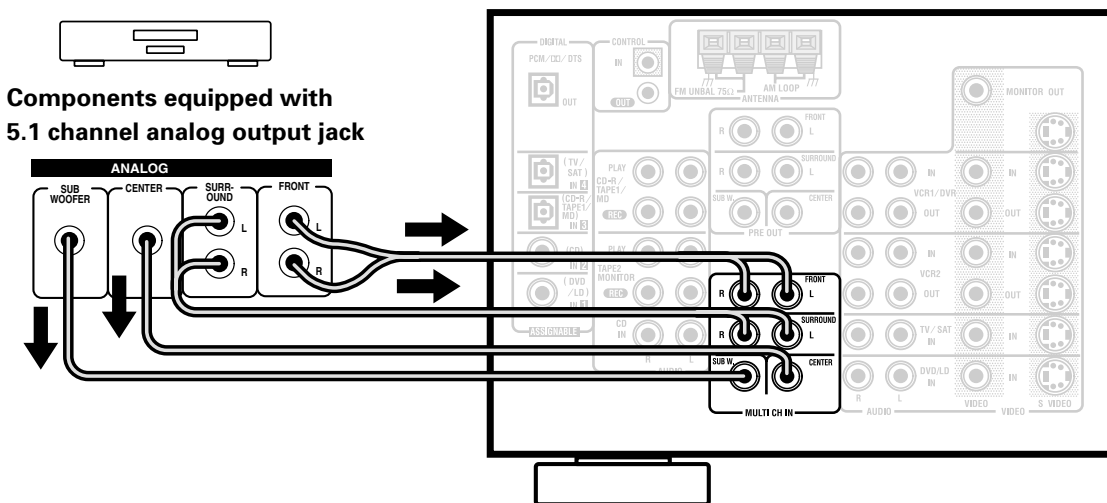

## Connecting the Radio Antennas

Connect the supplied FM wire antenna and the AM loop antenna to the antenna terminals as shown below. These antennas should provide adequate reception quality in most cases, but connecting outdoor antennas should noticeably improve sound quality.

Before making or changing the connections, switch off the power and disconnect the power cord from the AC wall outlet.

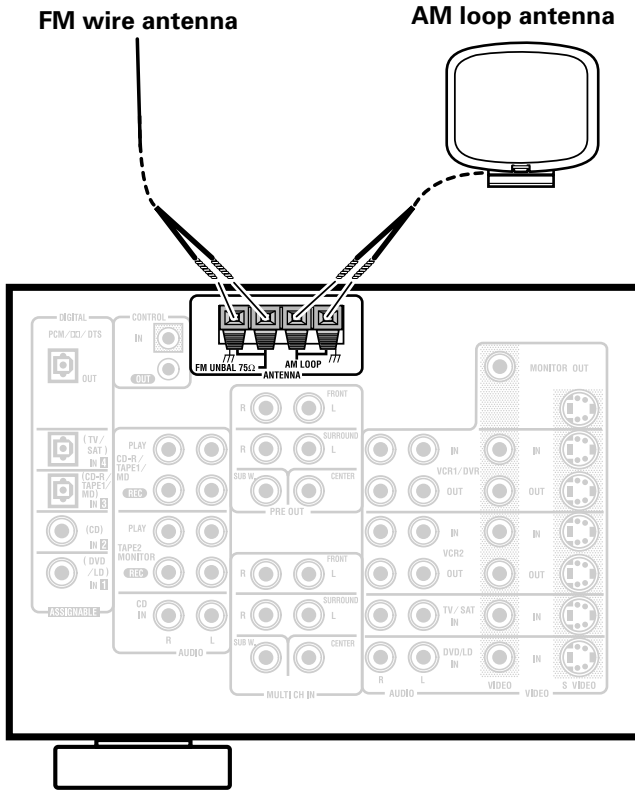

### ■ AM loop antenna

- 1 Assemble the antenna.

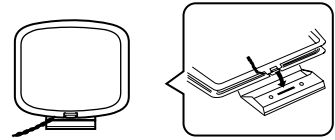

- 2 Twist exposed wire strands together and insert.

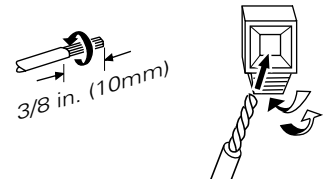

- 3 Attach to a wall, etc. (if desired) and face toward the direction providing the best reception.

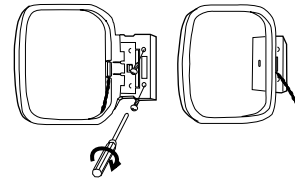

### Using external antennas

#### ■ To improve FM reception

Connect an external FM antenna.

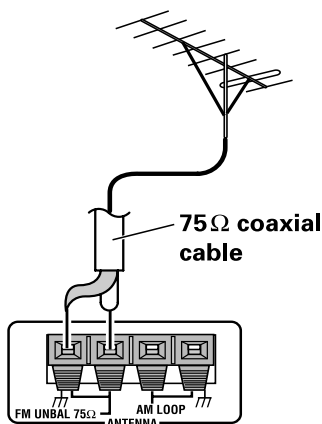

#### ■ To improve AM reception

Connect a 15-18 feet (5-6 meter) length of vinyl-coated wire to the AM antenna terminal in addition to the supplied AM loop antenna.

For best possible reception, suspend horizontally outdoors.

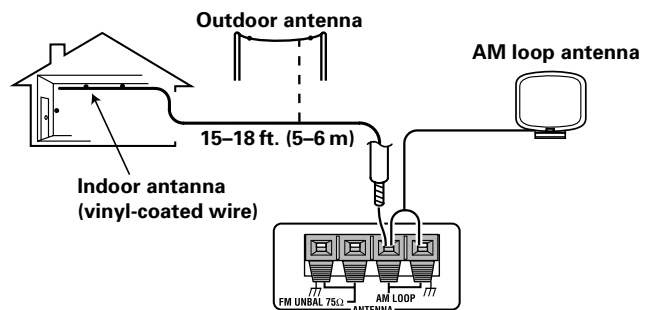

# Speakers

A full complement of six speakers is shown here but, naturally, everyone's home set up will vary. Simply connect the speakers you have in the manner described below. The receiver will work with just two stereo speakers (called "front" speakers in the diagram) but the receiver is designed to be used with at least three speakers.

In general, make sure you connect the speaker on the right to the right terminal and the speaker on the left to the left terminal. Also make sure the positive and negative (+/-) terminals on the receiver match those on the speakers. Before making or changing the connections, switch off the power and disconnect the power cord from the AC wall outlet.



The receiver has two speaker systems, A & B. A is the main system supporting the full complement of surround sound speakers. If you switch on both A & B speaker systems, only front speakers and the subwoofer will be audible. No sound will come from the center or surround speakers but multi channel sources will be down-mixed to the active speakers so no sound will be lost. Similarly, if you choose just the B system you'll only hear the front speakers connected to the B system and multi channel sources will be down-mixed to these two speakers.

For the VSX-33TX you can use speakers with a nominal impedance rated 6Ω-16Ω, see the following page.

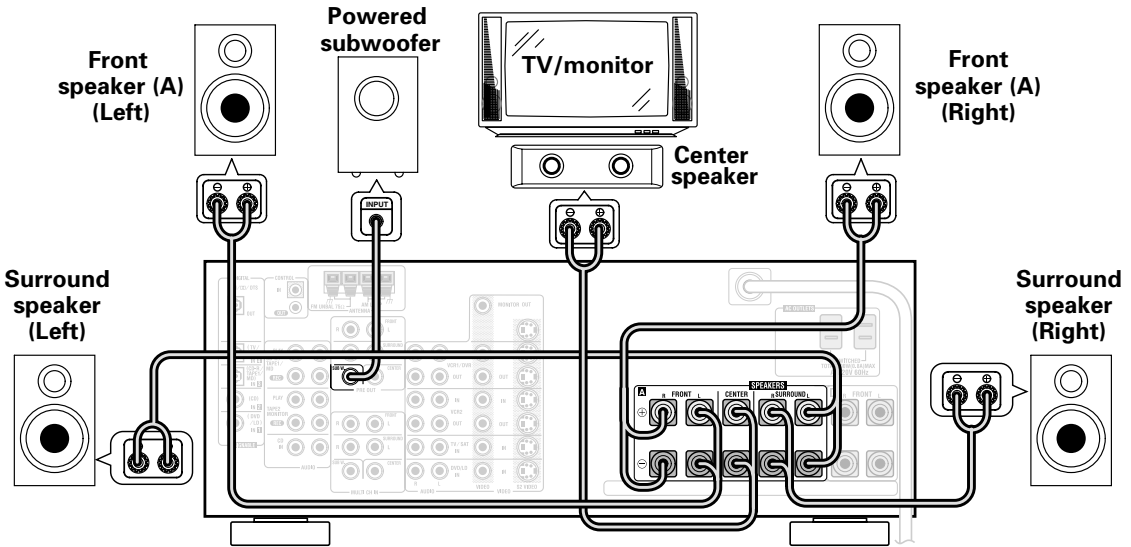

### ■ Speaker terminals

- ① Twist exposed wire strands together.
- ② Loosen speaker terminal and insert exposed wire.
- ③ Tighten terminal.

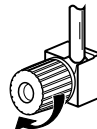
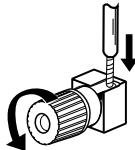
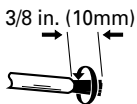

The speaker terminals also accept single banana plugs. (Refer to speaker manual for details.)

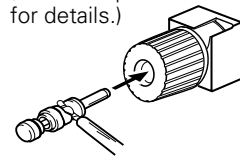

## Connecting Your Equipment

### Speaker impedance

You can change the speaker impedance for VSX-33TX but we recommend using speakers with an impedance of 8Ω-16Ω (the default setting). If you are using 6Ω- less than 8Ω impedance speakers, you need to change the impedance setting. Use any speaker rated between 6Ω-16Ω.

⏻ STANDBY/ON  
SPEAKERS

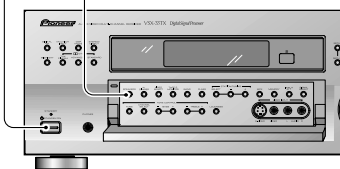

To check which impedance setting to hold down the SPEAKERS button for 2-3 seconds. You'll get a display like these telling you the speaker impedance setting.

**First turn the receiver off, then press the power button while holding down the SPEAKERS button.**

The receiver will re-set to the new impedance setting. You can choose the 8Ω-16Ω setting or the 6Ω-8Ω setting.



(This display indicates a 6Ω- less than 8Ω impedance setting.)



(This display indicates an 8Ω- 16Ω impedance setting.)

## Placing Your Speakers

Proper speaker placement is essential to realize the best sound from your system. The diagram and tips given here are just a rough guide; be sure to read the instructions that come with your speakers.

### Speaker placement

If you have a multiple speaker arrangement the placement of the speakers is extremely important. To achieve the best possible surround sound, install your speakers as shown below. Make sure all speakers are installed securely to prevent accidents and improve sound quality. Be sure to consult your speaker manuals for the best placement of the speakers. Some speakers are designed to be floor-standing but others benefit greatly from speakers stands which raise them off the floor.

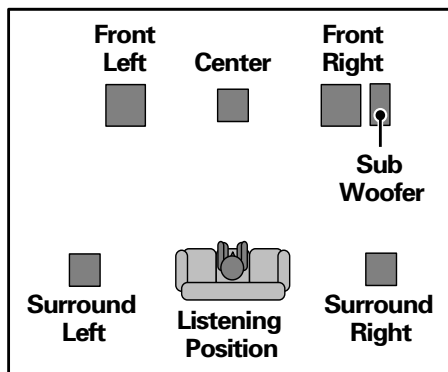
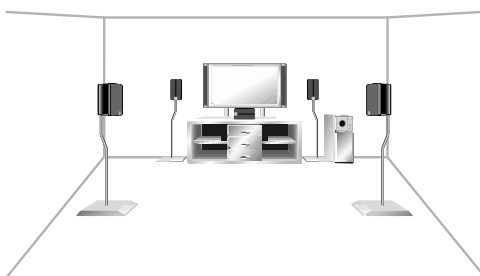

- Install the left and right front speakers at equal distances from the TV.
- When installing speakers near the TV, we recommend using magnetically shielded speakers to prevent possible interference such as distortion in the color of the TV screen. If you do not have magnetically shielded speakers and notice discoloration of the TV screen, place the speakers farther away from the TV.
- Install the center speaker above or below the TV so that the sound of the center channel is localized at the TV screen.

#### CAUTION:

When installing the center speaker on top of the TV, be sure to secure it with tape or some other suitable means. Otherwise, the speaker may fall from the TV due to external shocks such as earthquakes, and it may lead to endangering those nearby or damaging the speaker.

- If possible, install the surround speakers slightly above ear level.
- It may be difficult to obtain a cohesive surround effect if the surround speakers are installed farther away from the listening position than the front and center speakers.

## Connecting Additional Amplifiers

This receiver has more than sufficient power for any home use, but it is possible to add additional amplifiers to every channel of your system. Make the connections shown below to add amplifiers to power your speakers. Before making or changing the connections, switch off the power and disconnect the power cord from the AC wall outlet.

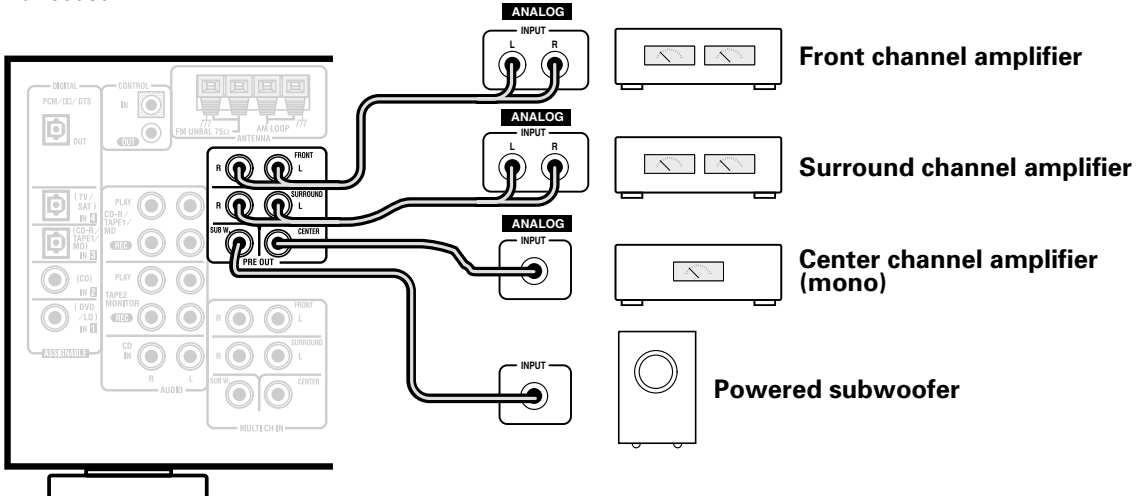

## Plugging In

Up to two components can be powered from this receiver. Two of the outlets are switched, which means that power is switched on and off with the receiver.

Before making or changing the connections, switch off the power and disconnect the power cord from the AC wall outlet.

After connecting all your components, plug the receiver's power cord into a standard wall power outlet.

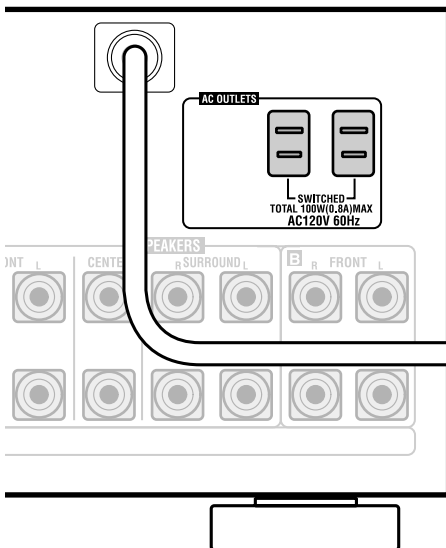

### Caution!

Power consumption of any equipment connected to the **switched** power outlets should not exceed **100W (0.8 A)**.

To avoid overheating, fire risk and possible malfunction, do not connect high-wattage appliances such as heaters, irons, monitors or TV sets to this unit's AC outlets.

Disconnect the receiver from the power outlet when it's not in regular use, for example, when on vacation.

### Caution!

Do not connect a monitor or TV to this unit's AC OUTLETS.

# Displays & Controls

## Front Panel

All the controls on the front panel are explained and/or referenced here. To open the front panel push gently on the lower third of the panel.

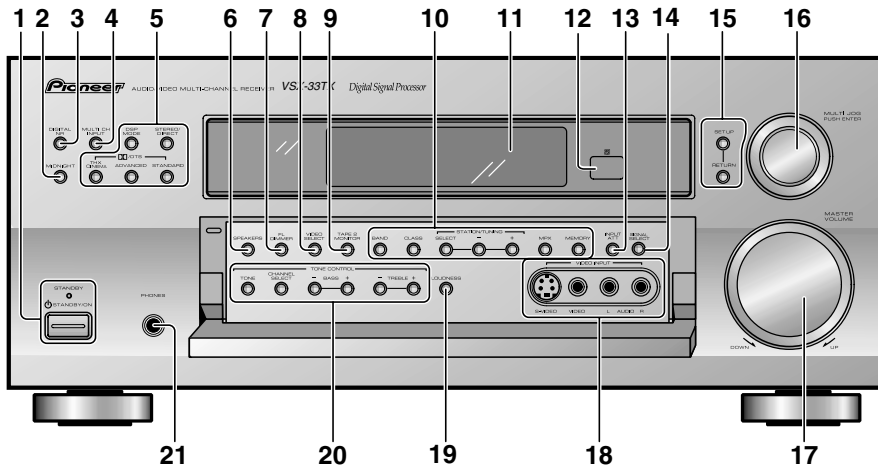

### 1 **STANDBY/ON button**

Press to switch the receiver ON or into STANDBY mode.

#### **STANDBY indicator**

Lights when the receiver is in STANDBY mode. (Please note that this receiver consumes a small amount of power [1.0 W] in the standby mode.)

### 2 **MIDNIGHT button (See p.46)**

Switches the MIDNIGHT mode on or off.

### 3 **DIGITAL NR button (See p.45)**

Switches the DIGITAL NR on or off (cannot be used in THX mode).

### 4 **MULTI CH INPUT (See p.48)**

Use to hook up an external component that can decode other types of signals and input them into the VSX-33TX.

### 5 **DSP MODE button (See p.40 – 41)**

Press repeatedly to select a DSP sound mode. (HALL 1, HALL 2, JAZZ, DANCE, THEATER 1, or THEATER 2, 5 CH STEREO). Use these modes to produce surround sound from standard (two channel) stereo sources and create different listening environments.

#### **STEREO/DIRECT button (See p.40, 49)**

Switches the receiver into STEREO mode if it was in a different sound mode (like ADVANCED THEATER) or toggles between DIRECT and STEREO mode. For more on STEREO mode see p.43.

DIRECT playback bypasses the tone controls and channel level for the most accurate reproduction of a program source.

### / **DTS buttons (See p.39, 71, 72)**

**THX CINEMA** – Use when listening THX-certified sources if you have THX-certified speaker setup or want to re-create a THX-style sound environment. It is also appropriate for Dolby Digital, Dolby Pro Logic or DTS sources. Those with surround back speakers can use all three THX modes, those without should use the THX CINEMA mode.

**ADVANCED** – Use to select one of the four Advanced Theater modes. Use to create certain types of sound environments when listening to Dolby Digital, Dolby Pro Logic or DTS sources.

**STANDARD** – Use for pure decoding of multi channel sources, especially Dolby Digital, Dolby Pro Logic or DTS sources.

### 6 **SPEAKERS (A/B) button**

Use to select the speaker system. A is the primary setting. It plays all speakers hooked up to the A system. A & B setting only plays the front speakers of both the A & B systems and the subwoofer. Multi channel sources will be down-mixed to these speakers so no sound will be lost. B setting only plays the front speakers connected to the B system and multi channel sources will be down-mixed to these two speakers. The button cycles through the speaker systems as follows: A⇒B⇒A&B⇒off

### 7 **FL DIMMER button**

Use to adjust the brightness of the fluorescent display (FL = fluorescent display). Four levels of the brightness ranging from very dim to very bright can be selected. Each press changes the brightness of the display.

**8 VIDEO SELECT button**

Switches the receiver between the various types of video input (DVD, VCR 1, etc.) while keeping the audio on a fixed source (for example, the CD function).

**9 TAPE 2 MONITOR button (See p.67)**

Selects the tape deck (MD recorder, etc.) connected to the TAPE 2 MONITOR inputs/outputs. Allows monitoring of a recording as it's being made.

**10 TUNER CONTROL buttons (See p.51-54)**

**BAND** – Press to select the AM or FM band.

**CLASS** – Press repeatedly to switch the preset station classes.

**TUNING SELECT** – Switches the STATION/TUNING button between station memory and frequency select modes.

**STATION -/+** – Selects station memories when using the tuner.

**TUNING -/+** – Selects the frequency when using the tuner.

**MPX** – Press to switch between auto stereo and MONO reception of FM broadcasts. When the broadcast signal is weak, selecting MONO will improve the sound quality.

**MEMORY** – Press to start the memorization of a preset station.

**11 Display (See p.26)**

**12 Remote sensor**

Point the remote control toward the remote sensor to operate the receiver.

**13 INPUT ATT button**

Use to lower the input level of an analog signal that is too powerful, thus causing the sound to distort (the OVER indicator will light when this is the case)

**14 SIGNAL SELECT button**

Press SIGNAL SELECT repeatedly to select one of the following:

**ANALOG** – Analog signal.

**DIGITAL** – Digital signal (DVD/LD, TV/SAT, CD, CD-R/TAPE 1/MD, VCR 1/DVR, VCR 2).

**AUTO** – This is the default. If there are both analog, digital, the receiver automatically selects the best possible signal.

**15 MULTI-JOG CONTROL buttons**

**SETUP** – Press to switch the setup mode.

**RETURN** – Press to move back one step in the SETUP process.

**16 MULTI JOG dial**

You can use this dial for three purposes. In normal mode turn it to select a source component. Press it to switch the display between function mode and sound mode. When you press the SETUP button (15), you can use it to perform SETUP operations (turn to select, push to enter). The source indicators show the current component:

**DVD/LD** – DVD player or LaserDisc player.

**TV/SAT**– TV or satellite tuner.

**CD** – Compact Disc player.

**CD-R/TAPE1/MD** – CD recorder, Tape deck or Mini Disc recorder connected to CD-R/TAPE1/MD inputs/outputs.

**TUNER** – The built-in tuner.

**VIDEO** – Portable DVD player or game (etc.) connected to the VIDEO INPUT on the front panel.

**VCR1/DVR** – Video cassette recorder connected to VCR1/DVR inputs.

**VCR 2** – Video cassette recorder or other component connected to VCR 2 inputs.

**17 MASTER VOLUME**

Adjusts the overall receiver volume.

**18 VIDEO INPUT jacks (See p.15)**

**S-VIDEO** : Video input for connecting a Portable DVD player or game (etc.), that has an S-Video out.

**VIDEO / AUDIO (L/R)** : Video input for connecting a Portable DVD player or game (etc.),that has standard video/audio outputs.

**19 LOUDNESS button (See p.46)**

Switches the LOUDNESS mode on or off (cannot be used in THX mode).

**20 TONE button**

This button has two functions. Firstly, it switches between TONE on and TONE BYPASS, which bypasses the tone circuitry. Secondly, you need to press the button before using the CHANNEL SELECT buttons to adjust the BASS & TREBLE(cannot be used in THX mode).

**CHANNEL SELECT button**

Switches the tone adjust controls between the FRONT, CENTER, SURROUND speakers. You can then use the BASS and TREBLE controls to adjust the sound.

**BASS (-/+) button (See p.47)**

Use to adjust low frequencies.

**TREBLE (-/+) button (See p.47)**

Use to adjust the high frequencies.

**21 PHONES jack**

Connect headphones for private listening (no sound will be heard through the speakers)

# Remote Control

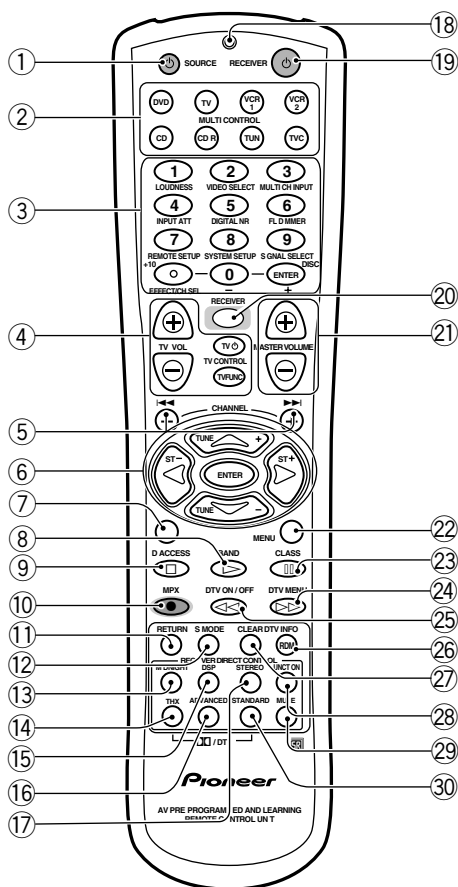

- ① **SOURCE** button  
Use to turn on/off other components connected to the receiver.
- ② **MULTI CONTROL** buttons  
Use to put the receiver/remote control in the stated mode.  
For other equipment controls, see Controlling the Rest of Your System on pages 55-59.
- ③ **Number/MODE** buttons  
Use the number buttons to select the radio frequency in tuner DIRECT ACCESS mode or the tracks in CD, DVD mode etc.

Also, buttons marked with the following names have special functions. If you try to use one of these functions but the display flashes it means that function cannot be used in the current mode (for example DSP modes cannot be used when 5.1 CH setting is on).

**LOUDNESS** button  
Use to switch on the loudness. This feature is useful for getting good bass and treble sounds listening at low volumes.

**VIDEO SELECT** button  
Switches the receiver between the various types of video input.

**MULTI CH INPUT** button  
Use to hook up an external component that can decode other types of signals and input them into the VSX-33TX (see p.48).

**INPUT ATT** button  
Use to lower the input level of an analog signal that is too powerful, thus causing the sound to distort (the OVER indicator will light when this is the case).

**DIGITAL NR** button  
Press to switch Digital NR on or off. (See page 45)

**FL DIMMER** button  
Use to adjust the brightness of the fluorescent display (FL = fluorescent display).  
Four levels of the brightness ranging from very dim to very bright can be selected. Each press changes the brightness of the display.

**REMOTE SETUP** button  
Use to customize the remote control functions and the remote control itself. (See "Remote Control of Other Components" starting on p.55.)

**SYSTEM SETUP** button  
Use to set up the speaker and sound systems. For more information see "Setting Up for Surround Sound" starting on p.27.

**SIGNAL SELECT** button  
Press SIGNAL SELECT repeatedly to select one of the following:

- ANALOG** – Analog signal.
- DIGITAL** – Digital signal (DVD/LD, TV/SAT, CD, CD-R/TAPE 1/MD, VCR 1/DVR, VCR 2).
- AUTO** – This is the default. If there are analog, or digital signals input the receiver automatically selects the best possible signal.

**EFFECT / CH SEL** button  
For DSP/advanced theater sound modes use to put into the mode to add or subtract the amount of effect. For other sound modes use to select individual channels to increase or decrease channel level.

**EFFECT +/-** buttons  
Use to add or subtract the amount of effect in different DSP/advanced listening sound modes or the level of individual channels.

**ENTER** button (DISC)  
Use to enter commands into TVs or DTVs. For CD players use to change discs.



**④ THE FOLLOWING FOUR SETS OF BUTTONS ARE DEDICATED TV CONTROL. THEY ARE ONLY USED FOR CONTROLLING YOUR TV.**

**TV VOL +/- buttons**

Use to adjust the volume on your TV.

**TV  button**

Use to turn on the power of the TV.

**TV FUNC button**

Use select the TV function.

**⑤   /CHANNEL +/- buttons**

Use to adjust the volume on your TV.

**⑥  (+) /  (-) /  /  /ENTER buttons**

Use to set up surround sound, speakers levels & settings, and other set up features see p.27-38). Specific use of these buttons is described in conjunction with the operations they perform. For more information see each individual section. Also, use these buttons to select radio frequencies.

**⑦ GUIDE button**

Use to control the guide for TV/Satellite TV.

**⑧  button (BAND)**

Use to play components or use to switch between the AM and FM band when in TUNER mode. You can also use to select the green channel on digital TVs (DTV).

**⑨  button (D.ACCESS)**

Use to stop other components. Also use to directly access a radio station by pressing the number of the station you want. You can also use to select the blue channel on digital TVs (DTV).

**⑩  (MPX)**

Use to record other components. Also use to switch between auto stereo and mono reception of FM broadcasts. If the signal is weak then switching to MONO will improve the sound quality. You can also use to select the yellow channel on digital TVs (DTV).

**⑪ RETURN button**

Use to return to a previous setting during SETUP operations

**⑫ S.MODE button**

Use to select the screen mode.

**⑬ MIDNIGHT button (see page 46)**

Use to put receiver in MIDNIGHT mode. To use first press the RECEIVER button then operate this button.

**⑭ THX button (see page 39,41)**

Press to select the HOME THX CINEMA sound mode when listening to Dolby Digital, Dolby Pro Logic or DTS a variety of other sources.

**⑮ DSP button (See p.40-41)**

Press repeatedly to select a DSP sound mode. (HALL 1, HALL 2, JAZZ, DANCE, THEATER 1, or THEATER 2, 5 CH STEREO). Use these modes to produce surround sound from standard (two channel) stereo sources and create different listening environments.

**⑯ ADVANCED button**

Use to select one of the four Advanced Theater modes. Use to create certain types of sound environments when listening to Dolby Digital, Dolby Pro Logic or DTS sources.

**⑰ STEREO button (See p.40 & 49)**

Switches the receiver into STEREO mode if it was in a different sound mode (like ADVANCED THEATER) or toggles between DIRECT and STEREO mode.

DIRECT playback bypasses the tone controls and channel level for the most accurate reproduction of a program source.

**⑱ LED DISPLAY**

This display flashes when a command is sent from the remote control to the receiver. It also flashes at other times, for example when teaching the receiver preset codes, with specific meanings.

**⑲ RECEIVER  button**

This switches between STANDBY mode and power ON for this receiver.

**⑳ RECEIVER button**

Use to switch the remote to the receiver control mode.

**㉑ MASTER VOLUME +/- buttons**

Use to set the overall listening volume.

**㉒ MENU button**

Use to get the various menus for your TV or DTV.

**㉓  button (CLASS)**

Use to pause components or use the CLASS feature to switch between the three banks (classes) of station memories. You can also use to select the red channel on digital TVs (DTV).

**㉔  button (DTV MENU)**

Use to fast forward search on CDs etc. Also you can access the DTV menu with this button.

**㉕  button (DTV ON/OFF)**

Use to fast reverse search on CDs etc. Also use to turn DTV on/off.

**㉖ RDM (DTV INFO)**

Use to fast reverse search on CDs etc. Also you can access the DTV information with this button.

**㉗ CLEAR button**

This button clears the on-screen display (OSD) of a digital TV (DTV) menu.

**㉘ FUNCTION button**

Press to select a source. The button will cycle through all the possible sources.

**㉙ MUTE button**

Press to mute or restore the volume.

**㉚ STANDARD button**

Use for pure decoding of multi channel sources, especially Dolby Digital, Dolby Pro Logic, DTS sources.

## Display

All the display information is explained and/or referenced here.

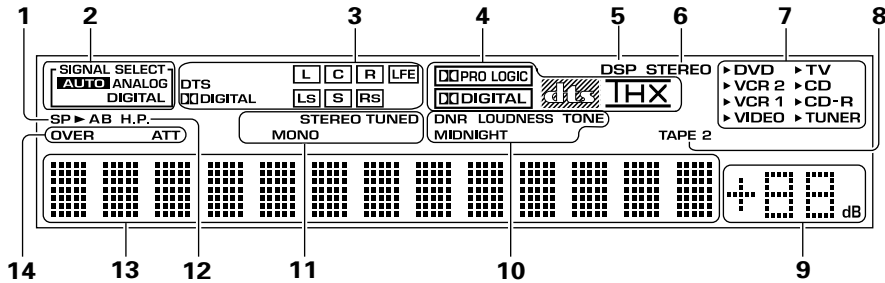

### 1 Speaker indicators

Light to indicate the current speaker system, A and/or B.

### 2 SIGNAL SELECT indicators

Light to indicate the input signal you selected.

**AUTO** : Lights when the receiver is set to select the input signal automatically.

**ANALOG** : Lights when analog signals are assigned.

**DIGITAL** : Lights when digital audio signals are selected.

### 3 Program Format indicator

**DIGITAL** : Lights when a source with Dolby Digital signals is played.

**DTS** : Lights when a source with DTS audio signals is played.

For Dolby Digital or DTS sources, these indicators change according to which channels are active in the source.

**L** – Left front channel.

**C** – Center channel.

**R** – Right front channel.

**LS** – Left surround channel.

**S** – Surround channel (mono).

**RS** – Right surround channel.

**LFE** – Low Frequency Effects channel.

### 4 /dts mode indicators

**DIGITAL** – Indicates multi channel playback of a Dolby Digital source.

**PRO LOGIC** – Lights when Dolby Pro Logic decoding is switched on.

**dts** – When the /dts mode on the receiver is on, this indicator lights to indicate playback of a DTS signal.

**THX** – Lights when the HOME THX CINEMA mode is selected.

### 5 DSP indicator (See p.40 – 41)

Lights when a DSP or Advanced Theater mode is selected.

### 6 STEREO indicator

Lights when a STEREO mode is selected.

### 7 Source indicators

► indicator lights at the selected source.

### 8 TAPE 2 indicator

Lights when the TAPE 2 monitor is on.

### 9 MASTER VOLUME indicator

Displays current volume level.

### 10 Sound control indicators

**DNR** – Lights when the digital NR is on.

**LOUDNESS** – Lights when the Loudness is on.

**TONE** – Lights when the Tone control is on.

**MIDNIGHT** – Lights when the Midnight mode is on.

### 11 Tuner indicators

**STEREO** – Lights when a FM stereo broadcast is received in the auto stereo mode.

**TUNED** – Lights when a broadcast is received.

**MONO** – Lights when the tuner is set to receive FM broadcasts with the mono mode selected.

### 12 H.P (headphones)

Lights when headphones are connected to the PHONES jack (speakers systems A and B both turn off automatically).

### 13 Character display

Shows current mode, status, etc.

### 14 Analog level indicators

**OVER** – When the source signal is analog, this lights if the signal is in danger of distorting. Press INPUT ATT to lower the signal level.

**ATT** – Lights when ATT is used to reduce the level of the analog source signal.

# Initial Setup

## Setting Up for Surround Sound

To ensure that this receiver works properly and you get the best possible surround sound, be sure to complete the following setup operations. You only need to make these settings once (unless you change the placement of your current speaker system, add new speakers or components, etc.).

These instructions are written using the remote control to make the settings but you can also use the multi jog dial, setup and return buttons on the front panel for the same purpose. Turn the multi jog dial left or right to instead of using the ▲ or ▼ arrow buttons and press the multi jog dial to enter the command.

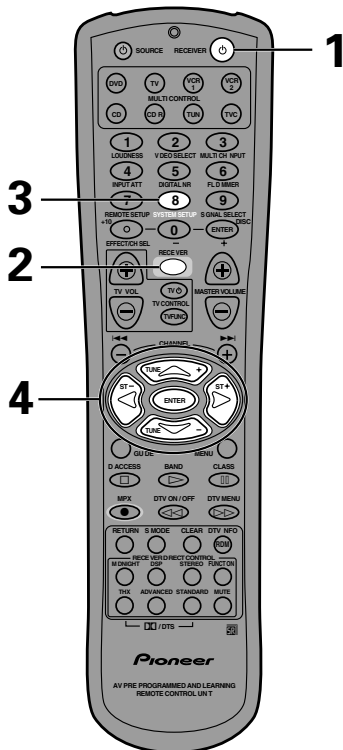

### 1 Press RECEIVER to turn the power on.

The STANDBY indicator goes out.

### 2 Press RECEIVER.

This switches the remote to the receiver control mode.

### 3 Press the **SYSTEM SETUP** (or **SETUP** on the front panel) button.



This display appears on the receiver.

- You can escape from this screen at any time by pressing the SYSTEM SETUP button again. None of the settings you made will be entered in this case.
- If don't enter any settings the receiver will revert back to it's previous state after three minutes.
- If you want to go back one level in the setup process press the RETURN button or ◀ button on the remote control.

### 4 Press the ▲ or ▼ arrow buttons (or use the **MULTI JOG** dial) to move the hand to the **second tier of setup modes** and choose the one you want. Then press the **ENTER** button (or the **MULTI JOG** dial) .

There are three second tier setup modes: **ASSIGN SETUP**, **SURROUND SETUP** and **FUNCTION RENAME**. The first of these, ASSIGN SETUP, is for telling the receiver which components are hooked up to which terminals and how they are connected. In the ASSIGN SETUP menu you must make the DIGITAL-IN-SELECT adjustments if you didn't follow the default settings when you hooked up your DVD/LD player.

We suggest you start with DIGITAL-IN-SELECT and adjust and make all the necessary adjustments here and then move on to the other entries in this menu and decide if you need to make these adjustments. It is likely you will not need to bother with any of the other things on this menu.

Next move on to the SURROUND SETUP menu and make all the necessary settings. It is essential you make these settings in order to get good surround sound .

The last set up menu, FUNCTION RENAME, lets you customize the receiver to match your home system.

The system set up modes explained here in a little more detail. The order follows that of the SYSTEM SETUP menu.

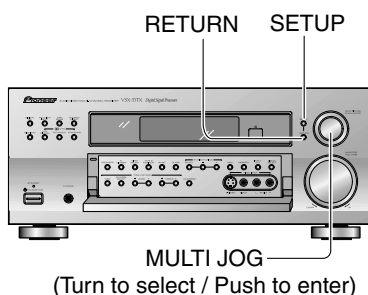

### ASSIGN SETUP:

#### Digital In Select (See p.29)

In order to use your digital components you must match the numbered digital input settings with the numbered digital jacks used by your digital components.

#### Multi Channel In Setting (See p.30)

This is for hooking up a multi channel external decoder that may give you higher quality when decoding discs. This feature lets you select adjustable to non-adjustable sound.

### SURROUND SETUP:

#### Speaker Setting (See p.31-32)

Use to specify the type and number of speakers you connected.

#### Channel Delay (See p.33)

Adding a slight delay to some speakers enhances sound separation and is particularly important for achieving a surround sound effect. You need to figure out the distance from your listening position to your speakers to add the proper delay.

#### Channel Level (See p.34-35)

Use to balance the volumes of your different speakers.

#### Crossover Network (See p.36)

This feature lets you select which bass frequencies will be sent to the subwoofer or front speakers.

#### Bass Level (See p.37)

Dolby Digital and DTS audio sources include ultra-low bass tones. Set the bass peak level as needed to prevent the ultra-low bass tones from distorting the sound from the speakers.

#### D-Range Control (See p.38)

This feature makes possible excellent surround sound effects when listening to Dolby Digital sources at low volumes.

### FUNCTION RENAME

This feature lets you rename specific "functions," which in this case stands for components like DVD/LD, VCR 1, etc. This is a useful feature for matching the remote control and receiver display exactly with your home setup.

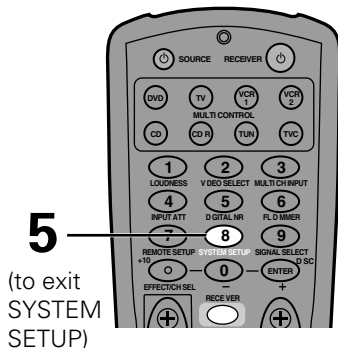

- 5 Go on to the next page to start the set up. If you don't want to make any settings go can exit this setup. To exit the SYSTEM SETUP MENU press the SYSTEM SETUP (or SETUP on the front panel) button again.**

## ASSIGN SETUP MENU

### Digital-In Select

In order to be able to use your digital equipment properly you need to assign digital inputs for each of the digital components you connected. Match the Digital 1-4 settings with the digital jacks 1-4 in accordance with what is connected to each digital jack. Check the digital jack numbers on the back of the receiver to make certain what component is in which jack (if necessary, see page 13 for more on digital connections). If continuing from the last page go to step 1. If starting fresh, complete steps 1-3 in "Setting Up for Surround Sound" (p.27) first.

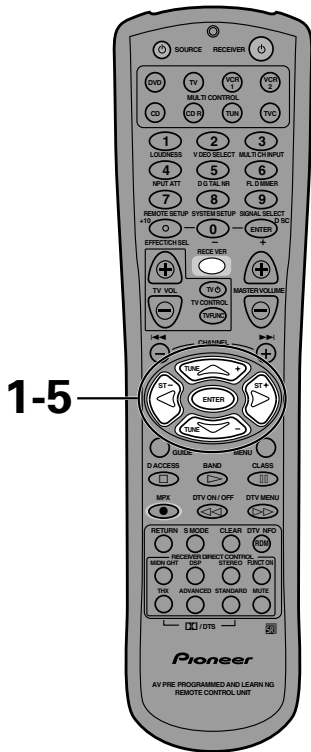

- 1 "Assign Setup" should be selected (if it isn't use the SYSTEM SETUP or SETUP buttons to select it).**

See "Setting Up for Surround Sound" on page 27 if you need more information.

Press the ENTER button.

- 2 "Digital In" will appear in the display. To go to the first Digital In setup press the ENTER button.**

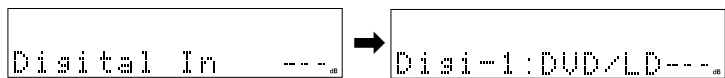

- 3 "Digi-1 DVD/LD" will appear. To change the digital input press ENTER. The input function selected will start to flash on the receiver's display.**

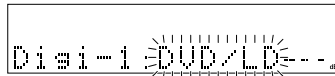

If you want leave it as is don't press ENTER, use the ▲/▼ buttons instead to move on to "Digi-2 CD" or another Digital In.

- 4 Use the ▲/▼ buttons (or the MULTI JOG dial) to choose the input function that matches the component hooked up to that digital terminal. Press ENTER when you've matched the two.**

The possible choices include: DVD/LD, CD, CD-R/TAPE 1/MD, TV/SAT, VCR 1, You cannot assign digital inputs to the TUNER, VIDEO, and TAPE 2 MONITOR functions.

If you assign a function (for example DVD/LD) that was previously assigned to a different Digital In the first Digital In will automatically revert to an OFF setting. This is because one function cannot be assigned twice.

Pressing ENTER moves you to the next DIGITAL IN. Repeat steps 3 & 4 until all the Digital Ins are set.

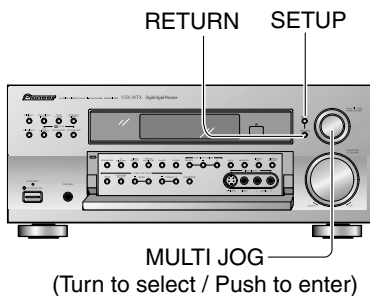

The default settings are:

DIGITAL IN 1: DVD/LD

DIGITAL IN 2: CD

DIGITAL IN 3: CD-R/TAPE 1/MD

DIGITAL IN 4: TV/SAT



The default settings for the DIGITAL INs are printed next to the jacks in parentheses on the back of the receiver.

- 5 Select "Dig-In End" with the ▲/▼ buttons (or the MULTI JOG dial) and press ENTER to go to Multi In Set.**

If you want to change a setting before proceeding use the arrow buttons to go back.

## Initial Setup

### Multi Channel In Setting

For most people this setting will not be necessary, if this is the case for you go on to the next setup. If you have a Multi Channel external decoder you can choose whether to have the sound level set to BYPASS, which bypasses the level adjust circuit or set to ADJUST, which goes through the level adjust circuit. If continuing from Digital In Select go to step 1. If starting fresh, complete steps 1-3 in "Setting Up for Surround Sound" (p.27) first.

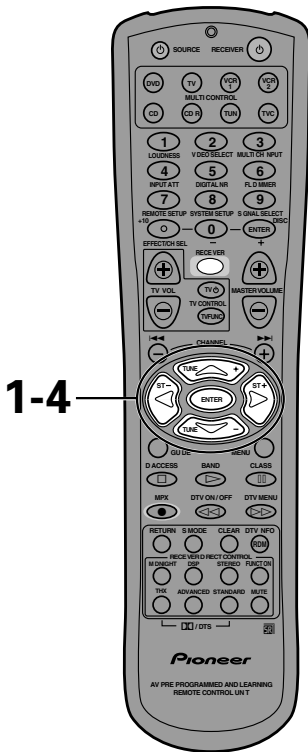

#### 1 Use the ▲/▼ buttons (or the MULTI JOG dial) to select "Multi In Set".

See "Setting Up for Surround Sound" on page 27 if you need more information.

Press the ENTER button.

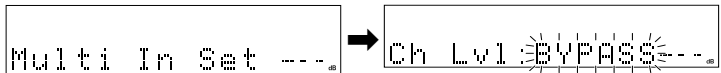

#### 2 Use the ▲/▼ buttons (or the MULTI JOG dial) to select the setting you want, BYPASS or ADJUST.

ADJUST

Use the ADJUST setting when you want to be able to control each channel level individually.

BYPASS

This setting is good for getting the cleanest possible signal. In this setting you won't be able to change each channel individually.

We recommend using BYPASS and the default setting is BYPASS.

#### 3 Press the ENTER button.

You will go to "Assign End".

#### 4 Press ENTER again and move on to "Surround Set" (the Surround Setup Menu).

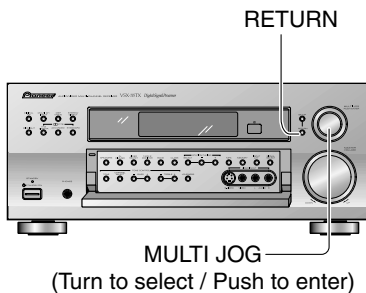

## SURROUND SETUP MENU

### Speaker Setting

Starting from this procedure use the SURROUND SETUP menu. To access the menu follow steps 1-3 on p.27 and in step three choose SURROUND SETUP (Surround Set is shown on the receiver's display). The steps below show you how to specify the type of speakers you connected. Use the ▲/▼ buttons (or the MULTI JOG dial) to make a selection from the display, and use the ENTER button to register the information.

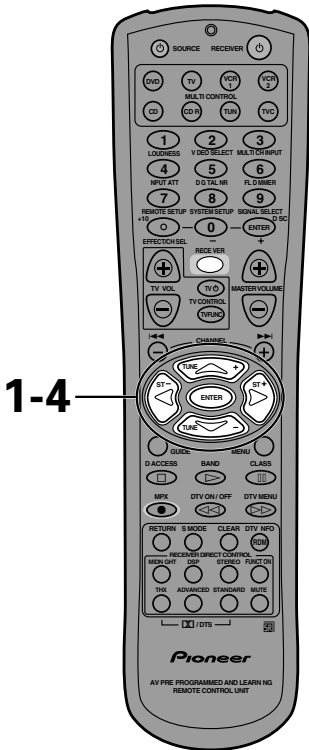

- 1 Select "Speaker Set" from the SURROUND SETUP MENU with the ▲/▼ buttons or MULTI JOG dial (if continuing from the last set up, it should already be selected). then press the ENTER button.**

See "Setting Up for Surround Sound" on the page 27 if you are unsure how to do this.

- 2 "Speaker Set" will appear in the display, press ENTER again to move to the settings.**

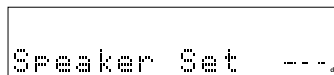

- 3 Select either the FREE or THX speaker setting mode with the ▲/▼ buttons (or MULTI JOG dial) then press ENTER.**

To specify each speaker individually select FREE.

If you connected a complete set of THX speakers select THX and skip step 5.

- 4 Specify the type of speakers you connected. See the explanations below for the meaning of each size.**

- ① Press ENTER. Use the ▲ or ▼ buttons (or MULTI JOG dial) to move the cursor to the speaker you want to adjust.
- ② Press ENTER to select that speaker. The speaker name will flash in the receiver's display.
- ③ Press ▲ or ▼ to move the setting to LARGE, SMALL, or NO depending on the size of your speakers (You can't select NO for the FRONT speakers. See below for detailed explanations).
- ④ Press ENTER.
- ⑤ Repeat ② and ④ for each speaker.

(see next page for explanations of sizes)

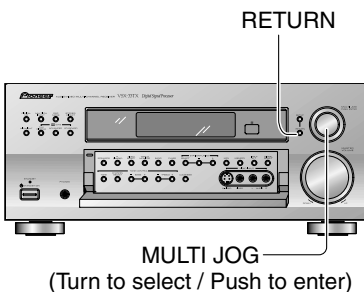

Depending on your choices the sound will be routed differently, read below for detailed explanations.

## FRONT (default setting is LARGE)

- Select SMALL to send bass frequencies to the subwoofer.
- Select LARGE if your speakers will reproduce bass frequencies effectively or if you did not connect a subwoofer. (If you select SMALL for the front speakers the subwoofer will automatically be set to YES. Also, the center and surround speakers cannot be set to LARGE if the front speakers are set to SMALL. In this case, all bass frequencies are sent to the subwoofer.)

## CENTER (default setting is LARGE)

- Select LARGE if your speaker will reproduce bass frequencies effectively.
- Select SMALL to send bass frequencies to the other speakers or subwoofer.
- If you did not connect a center speaker select NO. In this case, the center channel is output from the front speakers.
- If the front speakers are set to SMALL the CENTER speaker will automatically be set to SMALL.

## SURROUND (default setting is LARGE)

- Select LARGE if your speakers will reproduce bass frequencies effectively.
- Select SMALL to send bass frequencies to the other speakers or subwoofer.
- If you did not connect SURROUND speakers select NO. In this case, the sound of the surround channels is output from the front and center speakers.
- If the FRONT speakers are set to SMALL, the SURROUND speakers will automatically be set to SMALL.

## SUBWOOFER (default setting is YES)

- Selected YES you connected a subwoofer.
- If you did not connect a subwoofer select NO. In this case, the bass frequencies are output from the front or surround speakers.
- Choose the PLUS setting if you want stronger reproduction of deep bass sounds.
- If you select PLUS the bass frequencies that would normally come out the front and center speakers are all routed to the subwoofer.

## 5 Select "Sp Set End" with the ▲/▼ buttons or MULTI JOG dial and press ENTER to go to "Channel Delay".

Next, proceed to Channel Delay on the next page.

**If you want to change a setting before proceeding** use the arrow buttons to go back.

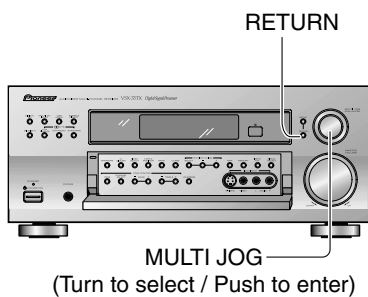
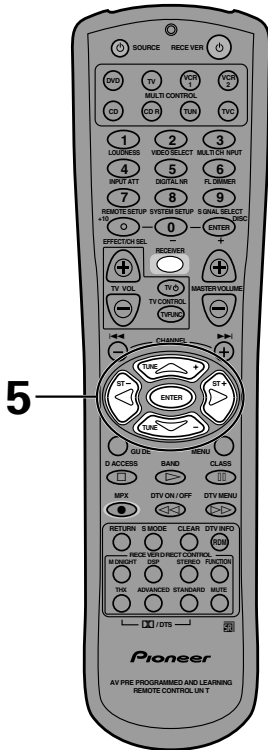

If you have a subwoofer and like lots of bass, it may seem logical to select LARGE for your FRONT speakers and leave the subwoofer selected. This may not, however, yield the best bass results. Depending on the size and shape of your room you may actually experience a decrease in the amount of bass due to what is called "low frequency cancellations." If you have a subwoofer, listen to the bass response with the FRONT speakers set to LARGE and SMALL alternatively and let your ears judge which sounds best.

The safest option in this case is to route all the bass sounds to the subwoofer by selecting SMALL for the FRONT speakers.



## Channel Delay

Adding a slight delay to some speakers is necessary to achieve a surround sound effect. You need to figure out the distance from your listening position to your speakers to add the proper delay. The following steps show you how to set the delay time for each channel by specifying the distances from your listening position to each speaker. Once you specify the speaker distances, the receiver calculates the correct delay times automatically. If continuing from Speaker Setting go to step 1. If starting fresh, complete steps 1-3 in "Setting Up for Surround Sound" (p.27) first.

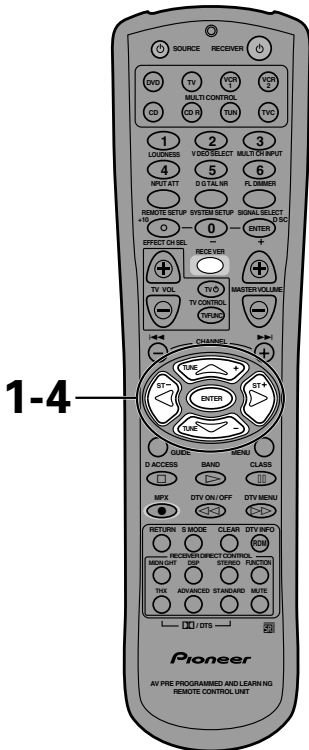

### 1 Select "Channel Delay" with the ▲/▼ buttons or MULTI JOG dial (if continuing from the last set up, it should already be selected).

See "Setting Up for Surround Sound" on page 27 if you are unsure how to do this.

Press the ENTER button.

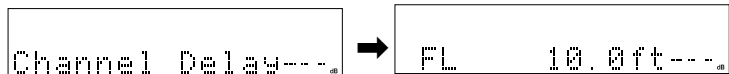

- The default setting is 10 ft.

### 2 Press ENTER again.

The distance will flash in the receiver's display.



### 3 Specify the distance from your listening position to each speaker using the commands below.

- ① Use the ▲/▼ buttons to adjust the speaker distance in half foot increments from 0.5 to 45 feet. The default setting is 10 feet.
  - ② Press ENTER.
  - ③ Repeat steps 2 and 3 for the rest of the speaker settings.
- Sound takes about 1 millisecond to travel 1 foot.

### 4 When you've finished the last setup and pressed ENTER, "Ch Delay End" should be selected. Press ENTER button again to send the information to the receiver and go to "Channel Level" settings.

Next, proceed to Channel Level on the next page.

**If you want to change a setting before proceeding** use the arrow buttons to go back.

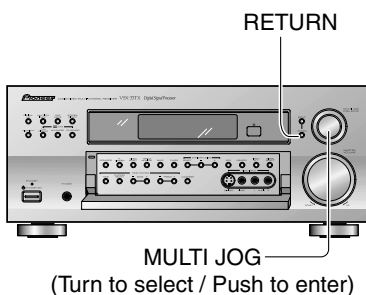

# Initial Setup

## Channel Level

The following steps show you how to balance the sound output level of your speakers. Proper speaker balance is essential for obtaining high quality surround sound. If continuing from Channel Delay go to step 1. If starting fresh, complete steps 1-3 in "Setting Up for Surround Sound" (p.27) first.

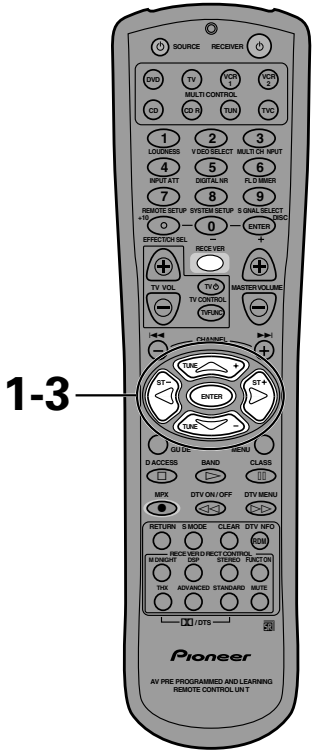

### 1 Select "Channel Level" with the ▲/▼ buttons or MULTI JOG dial (if continuing from Channel Delay, it will already be selected).

See "Setting Up for Surround Sound" on page 27 if you are unsure how to do this.

Press the ENTER button.

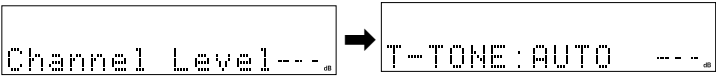

**NOTE : Be prepared! The test tone is output at a high volume level.**

MASTER VOLUME rotates to the reference position (0 dB) and the display on the receiver flashes TEST TONE. After a few seconds the test tone is output.

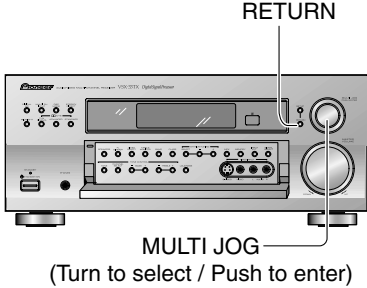

### 2 Select a TEST TONE mode.

- ① Press ▲/▼ (or the MULTI JOG dial) to move the cursor to AUTO or MANUAL.
- ② Press ENTER to start the test tone.

#### AUTO (automatic TEST TONE)

This mode switches the test tone between each speaker automatically.

The test tone is output in the following order:

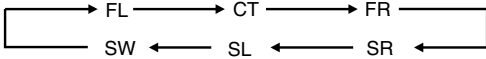

#### MANUAL (manual TEST TONE)

This mode lets you switch the test tone between each speaker manually. You can use this mode when you want to balance the speaker levels at a more leisurely pace.

### 3 After pressing ENTER it will take a moment for the volume to get to the reference position (0 dB) and the TEST TONE will be output.



(This display appears when you choose Auto test mode.)

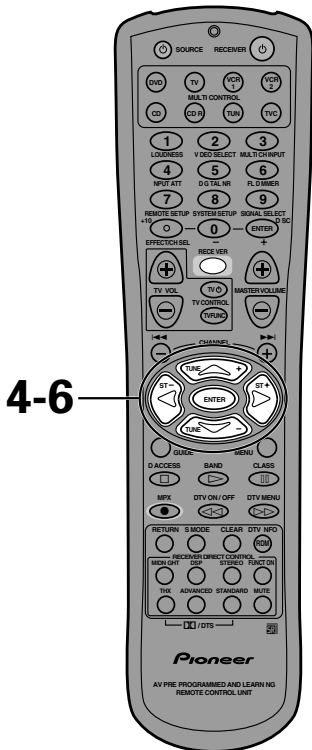

#### 4 Adjust speaker levels so that you hear the test tone at the same volume from each speaker when seated in your main listening position.

Note: The volume of the subwoofer tends to sound lower than it actually is, you may need to raise its level after testing the sound with actual soundtracks.

##### In AUTO mode

The receiver will automatically cycle through the speakers emitting a test tone from each one. It will continue to do this until you press ENTER to signify you have finished your adjustments.

##### In MANUAL mode

- ① Press ENTER
- ② Press the ▲/▼ buttons (or the MULTI JOG dial) to adjust the level of the speaker outputting the TEST TONE.
- ③ Press ENTER again to input the information and move to the next channel.
- ④ Repeat ①, ② and ③ for each speaker.

##### If you are using a Sound Pressure Level (SPL) meter

Take the readings from your main listening position and adjust the level of each speaker to 75 dB SPL (C-weighted/slow mode).

#### 5 When you have adjusted each speaker level and entered the information "Ch Level End" will be selected. Press ENTER .

It will again take a moment as the MASTER VOLUME returns to its original position.

#### 6 Press ENTER again to return to go to the "Crossover" settings.

Next, proceed to Crossover Network on the next page.

**If you want to change a setting before proceeding** use the ▲/▼ buttons (or the MULTI JOG dial) to go back.



Note that it is also possible to set channel levels temporarily. Then follow the same procedure as explained on this page. This function is designed to be used when you want to change the levels temporarily to raise the level of one channel. Using this method you can set speaker levels in different modes, such as, STEREO, and each DSP mode, independently. You should return the settings to their original state when done. Doing the set up procedures on this page will erase any temporary/independent level settings that have been made.

## Initial Setup

### Crossover Network

The following steps show you how to adjust the crossover network. The crossover network is the frequency at which the system divides the signal and sends the different parts (high, mid, low) to different speakers. Speaking precisely, this setting sets the cutoff point for the bass frequencies rerouted from your SMALL speakers to your subwoofer or speaker set to LARGE.

If continuing from Channel Level go to step 1. If starting fresh, complete steps 1-3 in "Setting Up for Surround Sound" (p.27) first.

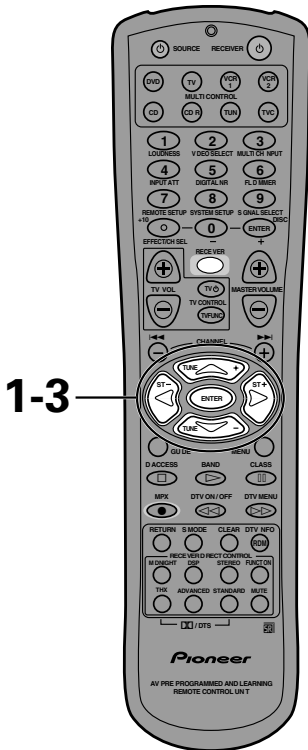

#### 1 Select "Crossover" with the ▲/▼ buttons or MULTI JOG dial (if continuing from CHANNEL LEVEL, it will already be selected).

See "Setting Up for Surround Sound" on page 27 if you are unsure how to do this.

Press the ENTER button.

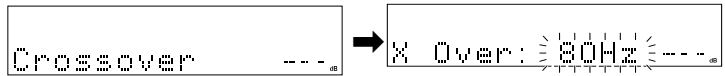

• The default setting is 80 Hz.

#### 2 Specify the crossover frequency for your small speakers.

Setting speakers to SMALL in "Speaker Setting" sends the respective channel's bass frequencies to the subwoofer (or LARGE speakers). The present function lets you determine which frequencies will be sent to the subwoofer or LARGE speakers.

① Use the ▲/▼ buttons (or the MULTI JOG dial) to select 80 Hz, 100 Hz, or 150 Hz.

##### 80Hz

Sends bass frequencies below 80 Hz to the subwoofer (or LARGE speakers).

##### 100Hz

Sends bass frequencies below 100 Hz to the subwoofer (or LARGE speakers).

##### 150Hz

Sends bass frequencies below 150 Hz to the subwoofer (or LARGE speakers).

Experiment with the different settings to see which sounds best to you.

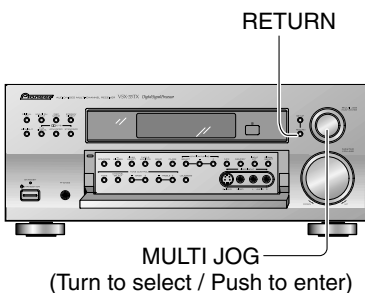

#### 3 Press ENTER to send the information to the receiver and got to the "Bass Level"

Next, proceed to Bass Level on the next page.

If you want to change a setting before proceeding use the ▲/▼ buttons to go back.

## Bass Level

The LFE (Low Frequency Effect) channel in Dolby Digital or DTS program sources can produce heavy ultra-low bass tones that may exceed the capabilities of your speaker system. The following steps show you how to set a maximum output level for the LFE channel. If continuing from Crossover Network go to step 1. If starting fresh, complete steps 1-3 in "Setting Up for Surround Sound" (p.27) first.

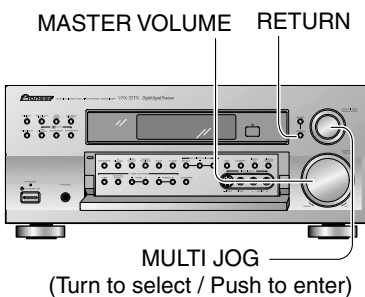
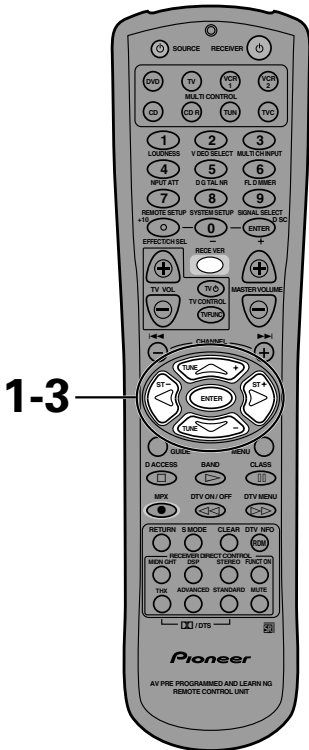

### 1 Select "Bass Level" with the ▲/▼ buttons or MULTI JOG dial (if continuing from Crossover Network it will already be selected).

See "Setting Up for Surround Sound" on page 27 if you are unsure how to do this.

Press the ENTER button.

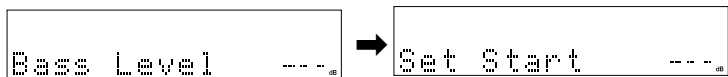

### 2 Output the test tone for the LFE channel and specify the peak level.

If your subwoofer has a volume control, set it to the middle position before proceeding.

- ① SETTING START will be selected, press ENTER

The MASTER VOLUME goes to the reference level [MIN (—dB)]. Then the test tone is output to the subwoofer, front or surround speakers.

- ② Use the ▲/▼ buttons (or the MULTI JOG dial) to select the Bass Level. Each press moves the level 1dB in a range of -80dB to +12dB. Gradually increase the level of the LFE channel until the test tone begins to distort. Then go back and leave the level setting at a point just before that.

- ③ Press the ENTER button.

It takes a few seconds for the MASTER VOLUME to return to its previous position.

### 3 "Bass Level End" will appear in the display. Press the ENTER button to go to "D-Range Cont."

Next, proceed to D-Range Control on the next page.

**If you want to change a setting before proceeding** use the ▲/▼ buttons (or the MULTI JOG dial) to go back.

## Initial Setup

### D-Range Control (Dynamic Range)

This feature makes it possible to enjoy full surround sound effects on Dolby Digital sources even at low volumes. It does this by compressing the dynamic range. Dynamic Range is the difference between the loudest and the softest sounds in any given signal. Compressing the range plays sounds so the quieter ones are audible and the louder ones don't get distorted or become overpowering. This feature only applies to Dolby Digital sources but the MIDNIGHT LISTENING mode accomplishes the same end for a variety of sources (see page 46). If continuing from Bass Peak Level go to step 1. If starting fresh, complete steps 1-3 in "Setting Up for Surround Sound" (p.27) first.

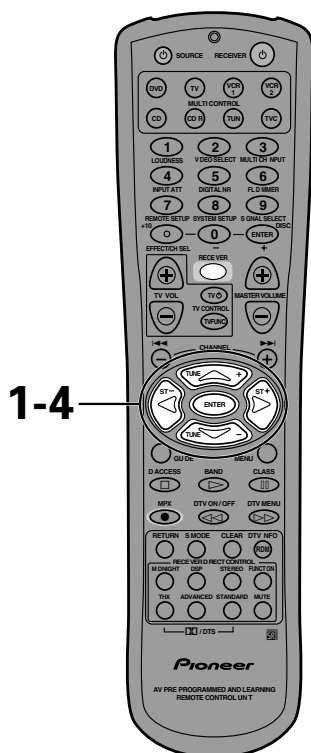

#### 1 Select "D-Range Cont" with the ▲/▼ buttons or MULTI JOG dial (if continuing from Bass Level, it will already be selected).

See "Setting Up for Surround Sound" on page 27 if you are unsure how to do this.

Press the ENTER button.



- The default setting is OFF.
- If listening at loud volumes we recommend turning the D-Range Control OFF.

#### 2 Use the ▲/▼ buttons (or the MULTI JOG dial) to choose OFF, MID or MAX.

#### 3 Press the ENTER button.

If you want to change a setting before proceeding

Choose a new D-Range Control setting using the ▲/▼ buttons (or the MULTI JOG dial).

You may need to experiment with different Dolby Digital sources before you can use the D-Range Control setting to suit your low volume listening needs.

#### 4 "Surr Set End" will appear in the display. Press the ENTER button.

You will go on to the "Rename" tier of the setup menus. This is not necessary for the basic operation of the receiver but lets you customize your system (see p.65-66). If you don't want to rename anything at this time use the ▲/▼ buttons (or the MULTI JOG dial) to select "Setup End" and press ENTER.

This setting completes the surround setup.

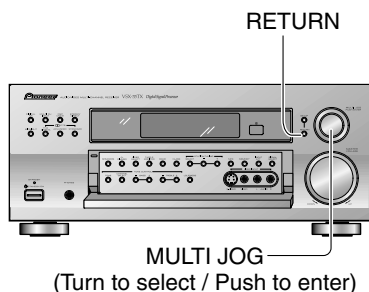

# Basic Playback

## Learning about the Sound Modes

The sound modes are explained here.

There are three cinema modes: STANDARD, HOME THX CINEMA, and ADVANCED THEATER. These are designed to be used with multi channel surround sound audio/visual sources (like DVDs and LDs). Intrinsic to home theater, these modes can deliver realistic and powerful surround sound that recreates the movie theater experience. You may need to experiment with them to see which settings suit your home system and personal tastes.

The DSP and STEREO modes are designed to be used with music sources but some DSP modes are also suited for film soundtracks. Again, try different settings with various soundtracks to see which you like.

### STANDARD mode

This mode is for pure decoding of Dolby Digital, DTS and Dolby Surround. No special effects are added. It is good for enjoying movies that have been recorded in Dolby Digital, DTS or Dolby Surround.

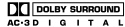
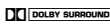
You can identify Dolby Digital software by the  or  marks. Most Dolby Surround software is marked , but unmarked software may also incorporate Dolby Surround.

### HOME THX CINEMA mode

THX is a set of technical standards created by Lucasfilm, Ltd. These standards were designed to emulate a film sound stage and thus reproduce, with the greatest possible accuracy, the soundtrack intended by the filmmakers.

### ADVANCED THEATER modes

The Advanced Theater mode is a newly designed system for enhancing movie soundtracks and other audio-visual sources. It incorporates the use of DTS as well as Dolby Digital into its sound processing. These functions switch on automatically when the source you are playing is encoded with DTS or Dolby Digital (bearing the  logo). There are four Advanced Theater settings that use DSP (Digital Signal Processing) to create different types of sound environments.

#### MUSICAL

This mode is primarily for music and adds a spacious feeling to the sound. A long delay time of reflected sounds, provides resonant tones which emulate a concert hall.

#### DRAMA

This mode is designed for movies with a lot of dialog. The elements of dialog are enhanced, making the characters seem more real. The mode also compresses the dynamic range somewhat so loud sounds do not overpower softer ones (compare this with the MIDNIGHT LISTENING mode explained on p.46).

#### ACTION

This mode is designed for action movies, which generally use lots of sound effects. The mode enriches the sound to make it more realistic and extends the parameters to pick up high and low sound effects.

#### 5-D THEATER

This mode is especially designed to give sound depth to stereo sources. The overall effect builds a dynamic and broad sound space, allowing two-channel (stereo) signals to faithfully imitate a five speaker sound. The mode should be used in conjunction with Dolby Pro Logic for sources bearing the  mark.



When a Dolby Digital soundtrack is played back the Dialog Normalization function of the receiver activates automatically. Dialog Normalization is a Dolby Digital function that establishes the average dialog level for the program source being played. If the receiver's level does not match the average dialog level, first you see "DIAL NORM" flash in the receiver's display and next "OFFSET +4 dB" (as an example) will appear. In this example, the number +4 dB is the difference between the receiver's gain structure and the Dolby Digital average dialog level. To match the average dialog level, subtract or add the OFFSET level. For example, if the OFFSET level is +4 dB, the amplifier's output is 4 dB over the average recorded level.

## Basic Playback

### DSP modes

The DSP (Digital Signal Processing) modes allow you to transform your living room into a variety of different sonic environments when playing either two-channel or multi-channel sources.

#### HALL 1

Simulates the acoustic effects of a large concert hall. Suitable for classical music. A long delay time of reflected sounds, coupled with reverb effects, let the listener enjoy the dynamic and rich sounds characteristic of concert halls and powerful orchestral performances.

#### HALL 2

Simulates the acoustic environment of a very resonant concert hall. Rich reverberation and a full sound create the impression of a lively performance space.

#### JAZZ

Simulates the acoustic effects of a jazz club. Reflected sound is virtually below 100 msec so that the listener can enjoy a live band effect.

#### DANCE

Simulates the acoustic effects of a dance club. Features a strong bass sound. Reflected sound delay time is virtually below 50 msec, for the listener to enjoy the visceral power of dance music.

#### THEATER 1

Reproduces theater sound field effects without losing the localization of each channel. Theater effects can be enjoyed without losing Dolby Digital/ Pro Logic (Surround) effects when used in combination those formats (with movies bearing the  trademark).

#### THEATER 2

Simulates the acoustic environment of a theater while maintaining proper localization of each channel.

#### 5CH STEREO

Simulates the acoustic environment of a regular stereo while using all the speakers in the system to induce a rich, all-around sound.

### STEREO mode

Use the STEREO mode to enjoy standard (two-channel) stereo sound from the front left and right speakers. This mode is most like the sound reproduction you would get from a regular stereo receiver or amplifier that is not equipped to handle A/V formats as this one is. You might want to use this mode for listening to regular music sources (like CDs) but remember, you will only get sound from your front two speakers and possibly sub woofer.



# Selecting a Sound Mode

To ensure the best possible surround sound, be sure to complete the set up procedures described in "Setting Up for Surround Sound" (starting on page 27) before using the sound modes. This is particularly important when using the **DD** (Dolby) Digital or DTS sources. When using the sound modes, using SPEAKERS A will give the best results. If you use SPEAKERS B the sound will be down mixed to the two front B speakers.

## 1 Select the sound mode.

- For STANDARD → Press STANDARD
- For HOME THX CINEMA → Press THX(THX CINEMA)
- For ADVANCED THEATER → Press ADVANCED  
Each press changes the ADVANCED THEATER mode as follows:
  - MUSICAL → DRAMA
  - ← 5-D THEATER ← ACTION ←
- For DSP modes → Press DSP(DSP MODE) repeatedly  
Each press changes the DSP mode as follows:
  - HALL 1 → HALL 2 → JAZZ → DANCE
  - ← 5CH STEREO ← THEATER 2 ← THEATER 1 ←
- For STEREO → Press STEREO (STEREO/DIRECT)  
Each press changes the STEREO mode as follows:
  - STEREO → DIRECT

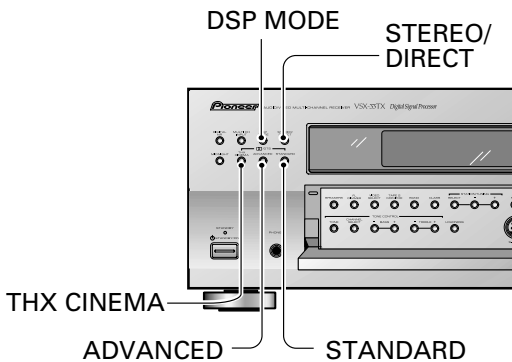
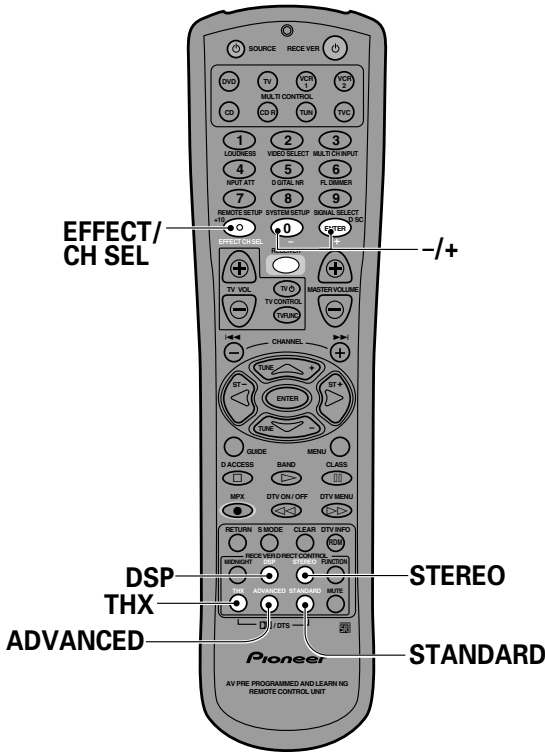

### memo

- The effects of ADVANCED THEATER mode can be adjusted in the range of 10 to 90 by pressing EFFECT +/- (The default setting is 70). Also, the effect level can be set in each ADVANCED THEATER mode by pressing the EFFECT (+/-) button.
- The amount of effect of each DSP mode can be adjusted in the range of 10 to 90 (the default setting value is 70) by pressing EFFECT +/-.
- 5CH STEREO modes cannot be changed.

# Playing Sources with Dolby Digital or DTS Sound

The following instructions show you how to play Dolby Digital or DTS sound sources with the VSX-33TX.

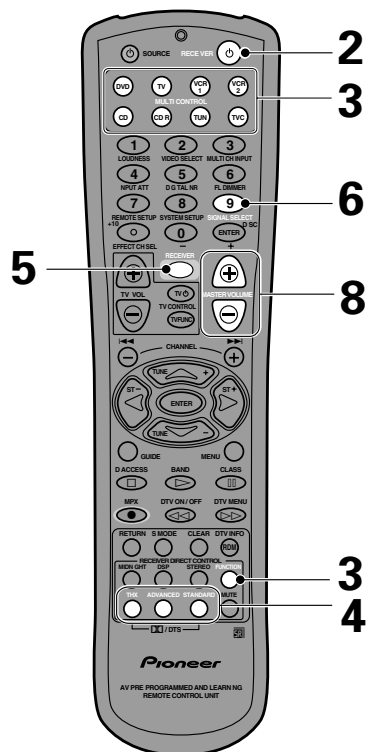

**1 Turn on the power of the playback component.**

**2 Turn on the power of the receiver.**

Be sure that the standby indicator turns off on the front panel.

**3 Press the MULTI CONTROL buttons or the FUNCTION button to select the source you want to playback.**

The FUNCTION button cycles through the sources in the following order:

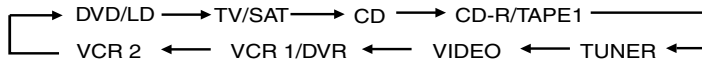

**4 Choose a sound mode by pressing THX, ADVANCED or STANDARD.**

The default setting is STEREO.

(For more see "Learning about the Sound Modes" and "Selecting a Sound Mode" on pages 39-41.)

**5 Press RECEIVER.**

The set the remote to receiver control mode.

**6 Press the SIGNAL SELECT button to select the input signal. Set to AUTO.**

(See "Switching Analog and Digital Signal Input" on page 44.)

**7 Start playback of the component you selected in step 1.**

**8 Adjust the volume by using the volume buttons on the remote control or the MASTER VOLUME on the front panel.**

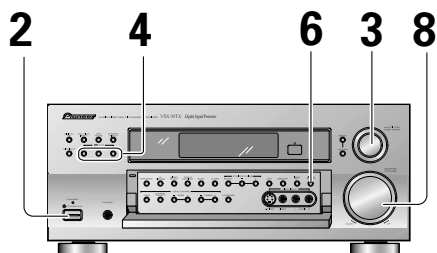

- We recommend using different modes for different types of DTS material. For watching movies, the THX or ADVANCED THEATER setting should provide the best results. For listening to music, the STANDARD, DIRECT, STEREO, or DSP modes should serve the listener best.
- Make sure you connect your DVD/LD or LD player with the RF demodulator. If your player has an RF output this will ensure you can use all LDs. Refer to p.14.

## Playing Stereo Sources

The following instructions show you how to use the receiver for stereo audio or audio-visual.

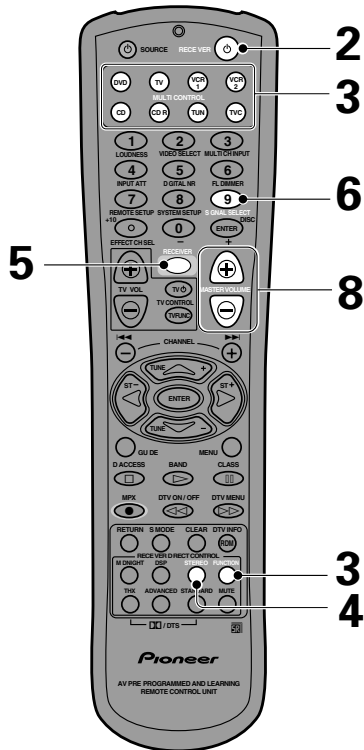

**1 Turn on the power of the playback component.**

**2 Turn on the power of the receiver.**

Be sure that the standby indicator turns off on the front panel.

**3 Press the MULTI CONTROL buttons or the FUNCTION button to select the source you want to playback.**

The FUNCTION button cycles through the sources in the following order:

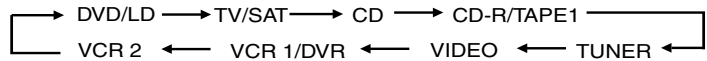

**4 Press the STEREO/DIRECT button to select the stereo mode.**

The STEREO indicator lights on the display.

**5 Press RECEIVER.**

The set the remote to the receiver control mode.

**6 Press the SIGNAL SELECT button to select the input signal. Set to AUTO.**

(See "Switching Analog and Digital Signal Input" on page 44 for more information.)

**7 Start playback of the component you selected in step 1.**

**8 Adjust the volume by using the VOLUME buttons on the remote control or the MASTER VOLUME on the front panel.**

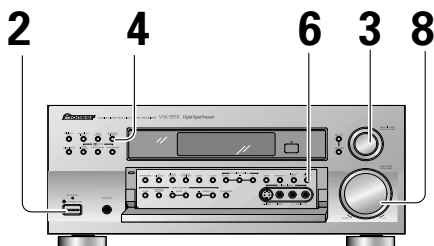

## Switching Analog and Digital Signal Input

This switch moves the input fed to the receiver between analog and digital sources. You need to take special care to switch to the appropriate input, when necessary. For example, the switch would have to be on DIGITAL to use DOLBY DIGITAL or DTS surround sound but it would have to be on ANALOG to record to the analog out jacks on the receiver. The default setting is AUTO (priority is given to a digital signal, if there is one).

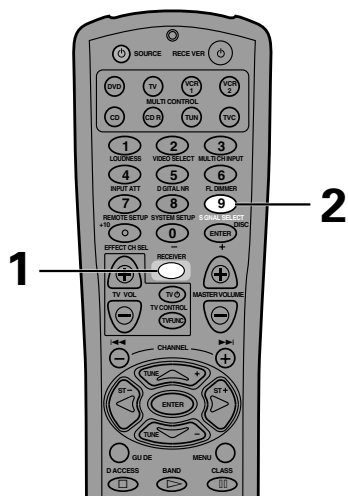

### 1 Press RECEIVER.

This switches the remote to the receiver control mode.

### 2 Press the SIGNAL SELECT button to select the input signal corresponding to the source component.

Each press switches the signal in the order below:



### 3 While SIGNAL SELECT is set to DIGITAL lights when a Dolby Digital signal is input, DTS lights when a DTS signal is input.

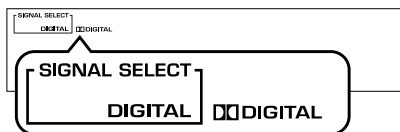
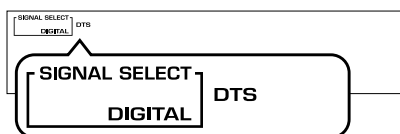
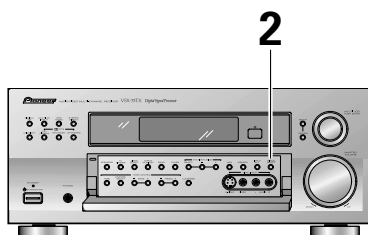

- In the AUTO setting, SIGNAL SELECT chooses the signal in the following order: DIGITAL, ANALOG.
- If the Digital-In Select (see page 29) choices are set to OFF, the SIGNAL SELECT will default to ANALOG.
- Because the audio from a karaoke microphone and LD recorded with analog audio only is not output from the digital output, set SIGNAL SELECT to ANALOG.
- This receiver can only playback Dolby Digital, PCM (32kHz, 44kHz, 48kHz, and 96kHz), and DTS digital signal formats. If you have some equipment that outputs digital audio in a format other than these you'll have to connect and playback via the receiver's analog inputs (make sure that SIGNAL SELECT is set to ANALOG).
- When an LD or CD with DTS is played back with the SIGNAL SELECT set in ANALOG, digital noise caused by playing back the DTS directly (with no decoding) is output. To prevent noise, you need to make digital connections (See pages 13 and 14) and set SIGNAL SELECT to DIGITAL or AUTO.
- Some DVD players don't output DTS signals. For more details, refer to the instruction manual supplied with your DVD player.
- The levels between analog and digital sources may vary so be careful with volume levels when switching between these two.

## Reducing Noise During Playback

To reduce extraneous noise switch on DIGITAL NR. This noise reduction can be used with every mode except THX, MULTI CHANNEL IN and DIRECT.

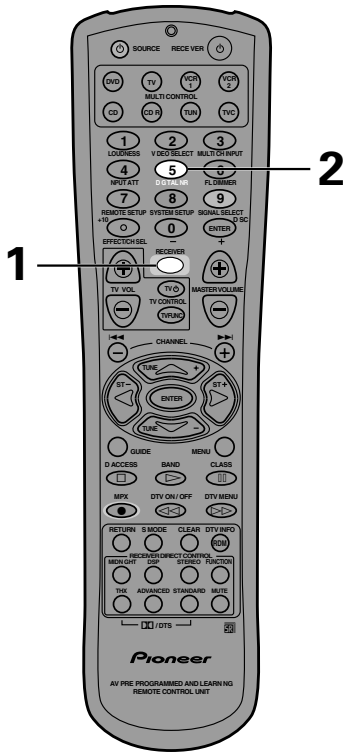

### 1 Press RECEIVER.

This switches the remote to the receiver control mode.

### 2 Press the DIGITAL NR button on the remote control or on the front panel.

Each press switches DIGITAL NR on or off.

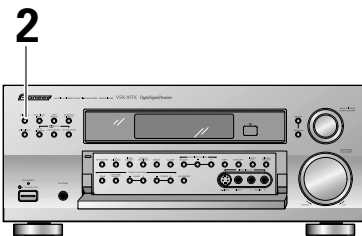

- In cases described below, noises may not be reduced even if DIGITAL NR is on.
  - Sudden noise
  - Extremely loud noise
  - Signals that do not contain many high frequencies
- DIGITAL NR is effective at and above levels shown below for each source.
- STEREO
  - analog input ..... 10 -18 dB
  - digital input ..... 10 -15 dB
  - AM/FM tuner ..... 10 -15 dB
  - DSP/ADVANCED/STANDARD/96kHz  
stereo ..... 6 -10 dB
- Depending on the condition of the source, there may not be a noticeable improvement in the quality of the sound.
- You can't use the DIGITAL NR mode with the THX or MULTI CH IN modes.
- If you press DIGITAL NR when in DIRECT mode the receiver switches to STEREO mode.

## Listening in Midnight Mode

This feature makes it possible to get excellent surround sound effects even when listening at low volumes. It can be used with a variety of surround sound sources and plays soundtracks so that the quieter sounds are audible while the noisier sounds don't become overly loud or distorted. It does this by bringing all the sounds in a given soundtrack closer together in volume. Compare this feature with the D-Range Control (only for Dolby Digital sources) on page 38.

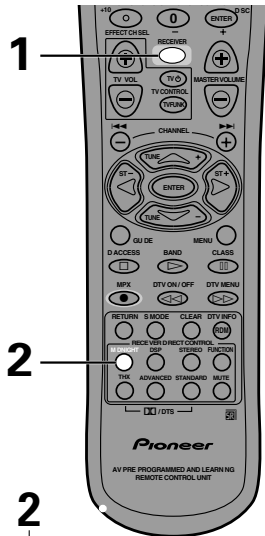

### 1 Press RECEIVER.

This switches the remote to the receiver control mode.

### 2 Press the MIDNIGHT button.

Each press switches MIDNIGHT LISTENING mode on or off.



- The effect adjusts itself automatically in accordance with the volume level.
- You can't use the MIDNIGHT LISTENING mode with the THX or MULTI CH IN modes.
- If you press MIDNIGHT when in DIRECT mode the receiver switches to STEREO mode.

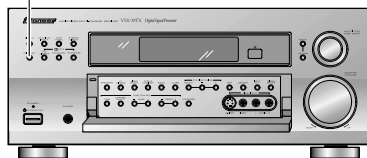

## Listening the Loudness Mode

The LOUDNESS mode allows you to boost the bass in a signal. It is useful for listening to music at low volumes.

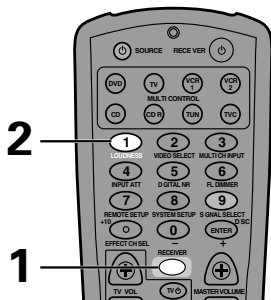

### 1 Press RECEIVER.

This switches the remote to the receiver control mode.

### 2 Press the LOUDNESS button.

Each press switches LOUDNESS mode between on and off.

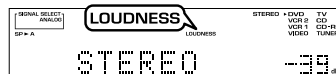

- You can't use the LOUDNESS mode with the MULTI CH IN or THX modes.
- If you press LOUDNESS in DIRECT mode the receiver will switch to STEREO mode.

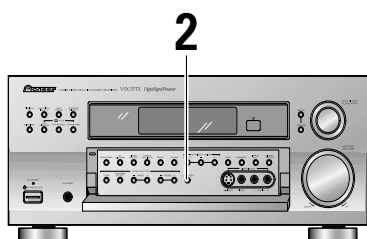

## Adjusting Bass and Treble

You can use BASS +/- or TREBLE +/- buttons to adjust the low and high frequencies for each individual set of speakers. If the receiver is in STEREO mode you can only adjust the FRONT speakers. In a surround mode (STANDARD, ADVANCED THEATER, etc.) you can adjust the FRONT, CENTER, SURROUND speakers. The TONE button can also be used to bypass the tone circuitry (see p.22-23).

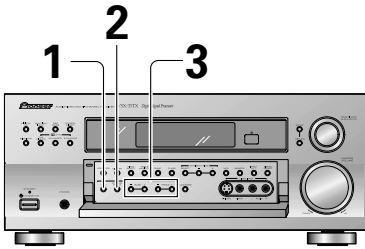

- 1 Press the **TONE** button on the front panel to put the receiver in **TONE ON** mode.

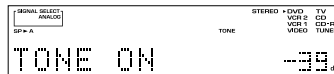

- 2 Press the **CHANNEL SELECT** button on the front panel to cycle through the different tone adjust modes.

The button cycles through the possibilities in the following order:

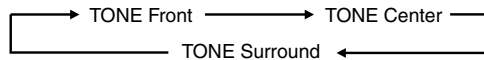

- 3 Use the **BASS** or **TREBLE (+/-)** buttons to adjust the low or high frequencies of each channel.

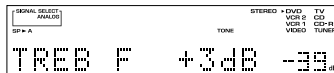

A few seconds after you finish adjusting the tone the receiver will revert to the sound mode it was in at the beginning of the process.



- The tone control can be adjusted in a range of  $\pm 6$  dB.
- The tone control cannot be adjusted in THX or MULTI CH IN modes.
- If you press TONE button in DIRECT mode, the receiver switch to STEREO mode and "TONE ON" appears in the display.

## MULTI CHANNEL IN Playback

MULTI CH IN allows you to connect an external decoder to enjoy certain types of specialized discs. To use MULTI CH playback follow the instructions below.

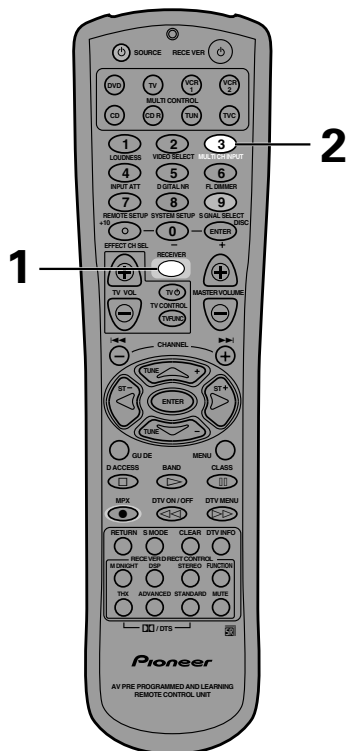

### 1 Press RECEIVER.

This switches the remote to the receiver control mode.

### 2 Press the MULTI CH INPUT button on the remote control or the front panel.

Each press switches the input between the previous mode and MULTI CH IN.



When MULTI CH IN is selected only the volume level can be set. All of this unit's other features (DIGITAL NR, etc.) cannot be used. Also, all speaker settings and other setup settings have no effect.

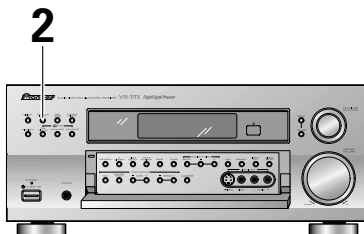

## 96 kHz 24 bit Performance

This receiver is capable of playing back advanced DVD discs which are recorded in 96 kHz/24 bit format (these are all stereo discs) and any source recorded in 96 kHz and up to 24 bit. The receiver will automatically read the format of the source and play accordingly (of course the SIGNAL SELECT will have to set to AUTO or DIGITAL to read the DVD soundtrack). When the receiver plays a 96 kHz disc "96 kHz" and whatever mode you're using (for example "STEREO," "DIRECT") will appear in the display.



- When a 96 kHz/24 bit disc is played back the volume may be louder than that of a normal disc.
- Some DVD players cannot play 96 kHz/24 bit discs. Check the manual of your DVD player to make sure.
- During this playback the player enters the STEREO mode and you can use the controls available in STEREO mode (LOUDNESS, MIDNIGHT, TONE controls, etc., see p.46-47).
- With 96 kHz/24 bit discs you are able to use MULTI CH IN playback and the TAPE 2 MONITOR.
- In 96 kHz/24 bit mode you can't use the STANDARD, ADVANCED THEATER, THX, or DSP modes.



## Direct Playback

This mode is for playing back a sound source in its purest form, no tone adjustments or other sound modes can be used.

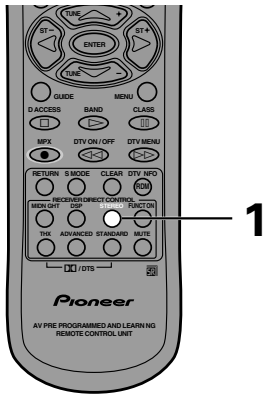

- 1 Use the STEREO button to alternate between STEREO or DIRECT mode (you can also use the STEREO/DIRECT button on the front panel).**

The DIRECT mode will give you the most accurate reproduction of two channel (stereo) sources but won't let you add any effects to the sound.



- None of the tone controls or other sound modes can be used with DIRECT playback.
- If the receiver is in a different mode than STEREO to start with the first push of the STEREO button will put it in STEREO mode. After that the button will toggle the receiver between STEREO and DIRECT mode.
- For more on this button see the explanation of STEREO mode on p.43.

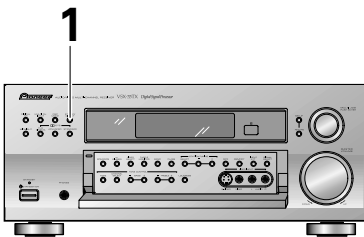

## Adjusting the Brightness of the Display

Use the FL DIMMER button to adjust the brightness of the fluorescent display (FL=fluorescent display).

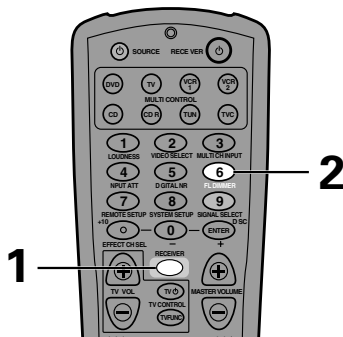

- 1 Press RECEIVER.**

This switches the remote to the receiver control mode.

- 2 Press the FL DIMMER button.**

Four levels of brightness ranging from very dim to very bright can be selected. Each press changes the brightness of the display. When rotating through the options, the default brightness can also be selected.

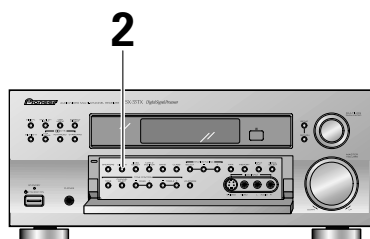

Please note: it is a feature of this unit that the fluorescent display will be brighter for a few seconds after you choose a function (like DVD/LD, CD, etc.) and then get softer. This will still happen when you adjust the brightness but the new setting will be the one the display softens to.

# DUAL MONO Setting

The dual mono setting can only be used when listening to Dolby Digital discs that have dual mono software encoded in them. Dual mono software usually is used to put two different soundtracks on one DVD. With this setting you can choose which channel in the dual mono setting you want to listen to. Thus, it is useful for soundtracks that have one language on one channel and a different language on the other. Remember this setting is only applicable if you are using Dolby Digital software with dual mono and want to isolate one of the channels therein. Otherwise, just ignore this function.

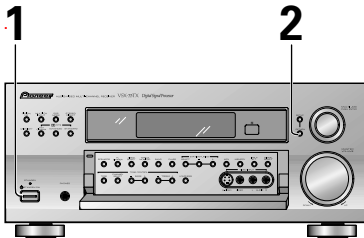

## 1 Turn the receiver ON.

## 2 Hold down the RETURN button for 3 or 4 seconds. The receiver will cycle through the three different dual mono settings for as long as you hold the button down.

Take your finger off the button when the mode that you want to use is displayed.

The different settings are: DUAL ch1, where you only hear channel 1; DUAL ch2, where you only hear channel 2; and DUAL ch1/ch2, where you hear both channels, but independently from different speakers.

The display will show dual mono for a while then revert to the sound mode you are in but you will still be listening to dual mono.

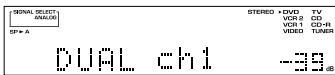

DUAL ch1 setting

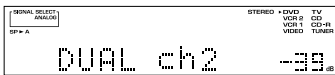

DUAL ch2 setting

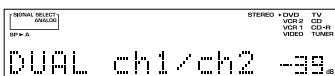

DUAL ch1/ch2 setting

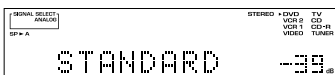

When DUAL MONO is playing with ch 1 selected the L will light. When playing with ch 2 selected the R will light. When playing with ch 1/2 selected the L and R will light.



The default setting is DUAL ch1.

# Using the Tuner

## Automatic and Manual Tuning

The following steps show you how to tune in FM and AM radio broadcasts using the automatic (search) and manual (step) tuning functions. If you already know the exact frequency of the station you desire, see "Direct Access Tuning" on the following page.

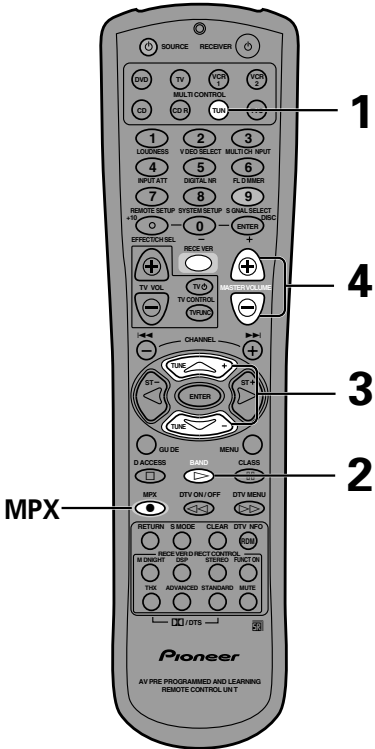

### 1 Press the TUN button

On the receiver, select "TUNER" with the multi jog.



### 2 Press BAND button on the remote or the front panel to select the band (FM or AM).

Each press switches the band: FM ↔ AM

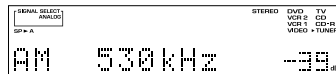

### 3 Tune in the station.

#### For Automatic Tuning

Press and hold TUNING +/- buttons for about one second, then release.

The tuner starts searching the selected band and stop automatically at the first station it locates. Repeat to locate other stations.

#### For Manual Tuning

- To change frequencies one step at a time, press TUNING +/- repeatedly.
- To change frequencies quickly, hold down TUNING +/- and release when you reach the frequency you desire.

### 4 Adjust the MASTER VOLUME buttons on the remote control or the MASTER VOLUME on the front panel.

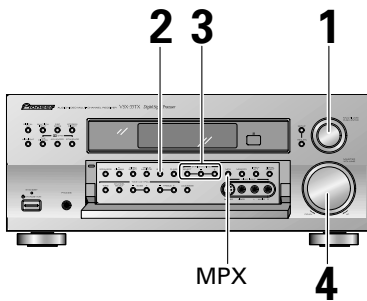

### MPX Mode

If the TUNED or STEREO indicators do not light when tuning an FM station, because the station is too far away or the broadcast signal is weak, press MPX on the remote control or front panel to switch to MONO reception. This should improve reception enough for you to enjoy the broadcast.

# Direct Access Tuning

The following steps show you how to tune directly to a specific frequency using the remote control.

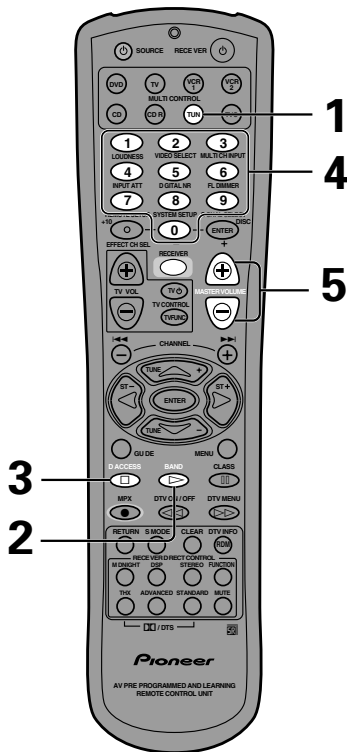

### 1 Press the TUN button

On the receiver, select "TUNER" with the multi jog.

### 2 Press the BAND button on the remote or the front panel to select the band (FM or AM).

Each press switches the band : FM ↔ AM

### 3 Press D. ACCESS button to activate the direct Access tuning mode.

The cursor blinks in the display on the front panel.

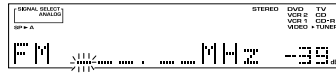

### 4 Use the Number buttons to enter the frequency of the station you want.

**Example:**

To tune station 106.00 (FM), press:

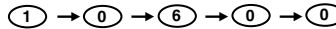

### To cancel before inputting the frequency

Press D. ACCESS button, and enter the frequency again.

### 5 Adjust the MASTER VOLUME buttons on the remote control or the MASTER VOLUME on the front panel.

## Memorizing Frequently Used Stations

The following steps show you how to memorize up to 30 radio stations in 3 classes (each holding 10 channels). When memorizing FM frequencies, the receiver also memorizes the MPX mode (STEREO or MONO).

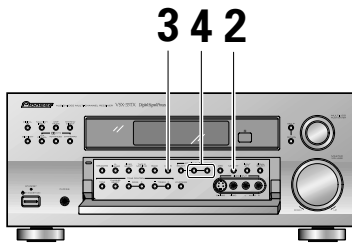

### 1 Tune in the desired station.

See "Automatic and Manual Tuning" or "Direct Access Tuning" on p.51 and 52.

### 2 Press the MEMORY button to activate the memory function.



### 3 Press the CLASS button repeatedly to select a class number.

Each press switches the display:

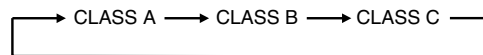

### 4 Press the STATION +/- buttons repeatedly to select a channel (0-9) within the respective class.



The station is memorized automatically after 5 seconds.

#### If you want to escape from MEMORY mode

Press the MEMORY button again.

**Repeat steps 1 through 4 to memorize up to 30 stations.**

# Recalling Memorized Stations

## Using the remote control

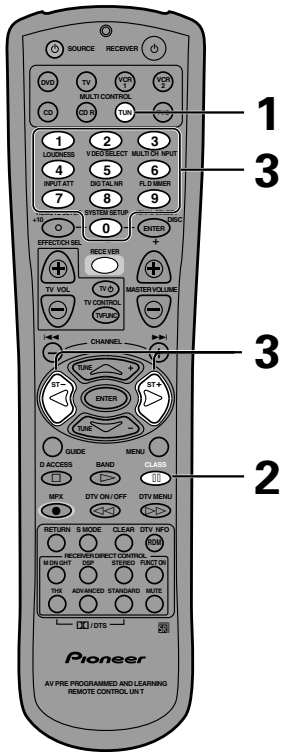

### 1 Press the TUN button

On the receiver, select "TUNER" with the multi jog.



### 2 Press the CLASS button repeatedly to select a class number.

Each press switches the display:

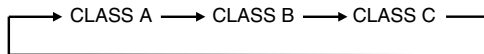

### 3 Use the NUMBER buttons to select the channel you want.

To select channel 7, press **7**.

To select channel 0, press **0**.

For example : If 99.50 MHz (FM) was memorized in class A at channel 7.



**To skip through each channel in order**

Press STATION -/+ repeatedly.

## Using the front panel

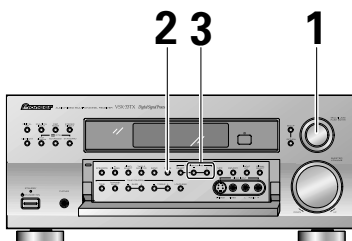

### 1 Select the TUNER function.

### 2 Press the CLASS button repeatedly to select a class number.

### 3 Press the STATION -/+ buttons repeatedly to select the channel you want.

# Remote Control of Other Components

## Setting Up the Remote Control

In addition to controlling the receiver, the supplied remote control can operate your other components (DVD, MD, VCR, TV, LD, CD, etc.). If your component(s) are listed in the "Preset Code List", simply recall the corresponding preset code.

### Recalling Preset Codes

The following steps show you how to recall preset codes for each MULTI CONTROL button. Once the preset code is assigned, pressing the button will automatically set the remote to operate the respective component.



- Refer to "Preset Code List" on pages 73 to 77 for the components and manufacturers available.
- Refer on pages 60 to 64 for detailed explanations on how to operate your other components.

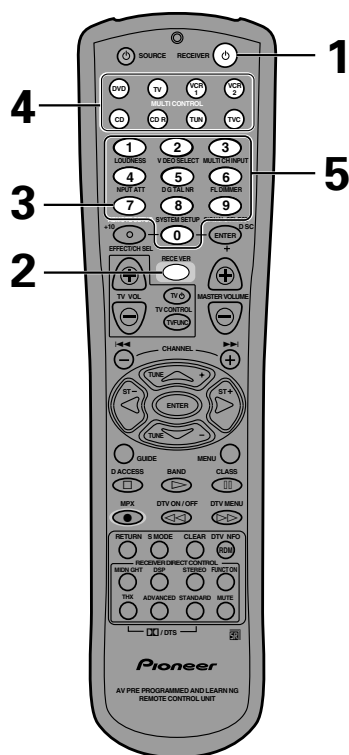

#### 1 Press RECEIVER to turn the power on.

The STANDBY indicator goes out.

#### 2 Press RECEIVER.

This switches the remote to the receiver control mode.

#### 3 Press the REMOTE SETUP button and hold for three seconds to select the preset mode.

The LED will blink twice.

#### 4 Press the MULTI CONTROL button for the component you want to control.

Each button can be set to control one of the following components.

- : DVD/LD player or DVD Recorder, VCR
- : TV, Satellite tuner or Cable TV tuner
- : CD player, CD-R, TAPE, MD, DAT
- : FM/ AM tuner

#### 5 Use the number buttons to enter the 4 digit setup code.

The LED will blink after each digit is input and will blink twice to confirm a valid code has been input.

If the LED shows one long blink it means an invalid code has been input. Check the preset code list and try again. If you are not able to input a preset code you can refer to page 56 to teach the remote control individual commands.

**Repeat steps 3 through 5 to assign preset codes for as many components as necessary.**

## Remote Control of Other Components

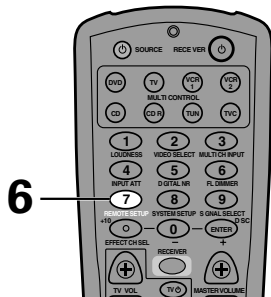

### 6 Press REMOTE SETUP to exit the preset mode.

The remote control returns to the previous operation mode. It will also return to the previous mode after ten seconds of inactivity.



- The Receiver button cannot be preset.
- You can only input a code for the component type written on each MULTI CONTROL button. See page 58 for information on how to program a different type of component than specified on the button.
- If you recall a preset code for the tuner (TUN MULTI CONTROL), you will not be able to control the built-in tuner of this receiver using the remote. To reset the remote to the built-in tuner, input the preset code 0080.

## Learning mode: Programming signals from other remote controls

If preset codes are not available for your component(s), or the available preset codes do not operate correctly, you can use this function to program in signals from the remote control(s) of your other component(s). This operation can also be used after recalling a preset code to program additional operations not covered in the preset codes.

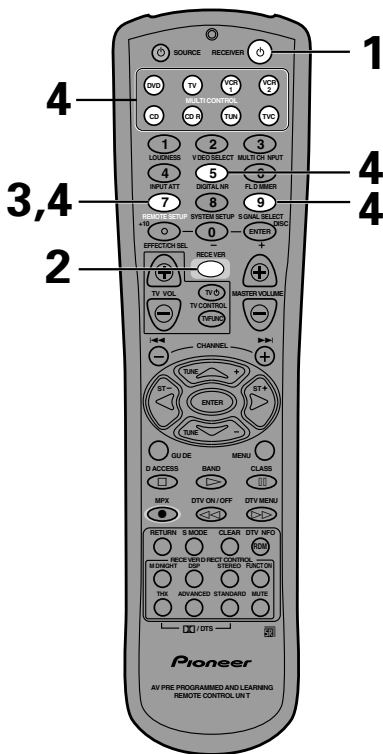

### 1 Press RECEIVER to turn the power on.

The STANDBY indicator goes out.

### 2 Press RECEIVER.

This switches the remote to the receiver control mode.

### 3 Press the REMOTE SETUP button.

The LED will blink twice.

### 4 Press the MULTI CONTROL button for the component you want to control and then press 9, 7, then 5 to select the LEARNING setup mode. The remote is ready to learn new commands from other remote controls.

The LED flashes rapidly.

#### To cancel LEARNING setup mode

Press SETUP button.

After ten seconds if no commands are entered the remote will revert to its previous mode.

### 5 Press the button to be programmed (for example the ► [play] button).



- 6 Point the remote controls at each other, about 1-2 inches apart, and press the button on the other remote control for the operation you want to program (only the buttons highlighted in the diagram on the left can be programmed).**

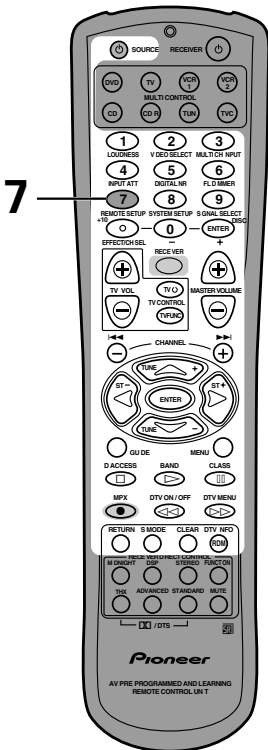

- ① Point the remote controls toward each other.
- ② Press the button on the other remote control corresponding to the operation you wish to program. The LED on this receiver's remote will go out and then blink twice when the operation is learned. Press the teaching key repeatedly, varying the distances between the remotes, until you see this receiver's remote blink twice, indicating the operation has been learned.

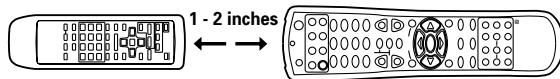

**To program additional operations for the current component**  
Repeat steps 3 and 4.

**To program operations for another component**  
Repeat steps 2 through 4.

- 7 Press REMOTE SETUP to exit the LEARNING setup mode**

After ten seconds of inactivity the remote control will automatically leave the LEARNING mode and revert to its previous mode.



Some commands from other remote controls cannot be learned, but in most cases the remotes just need to be moved closer together a farther apart.

# Programming a Different Component into a MULTI CONTROL button

This feature changes a selected Multi Control button to a different component. For example, if you don't have a second TV, but you do have a second DVD, you could reassign the TV Multi Control to DVD so that DVD control buttons are available when you select TV.

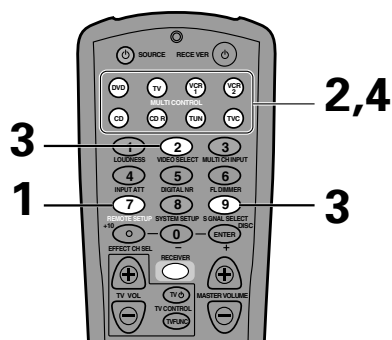

### 1 Press REMOTE SETUP and hold for three seconds.

The LED on the remote will blink twice.

### 2 Press the MULTI CONTROL button which you want to change.

For the example above, press TV.

### 3 Press 9, 9, then 2.

### 4 Press the MULTI CONTROL button which you want to be duplicated.

In the above example, press TV. The LED will blink twice. The TV button will now make the remote function as a DVD controller.

Remember to assign the correct preset code for your equipment (the default is for Pioneer equipment).

## Checking Preset Codes

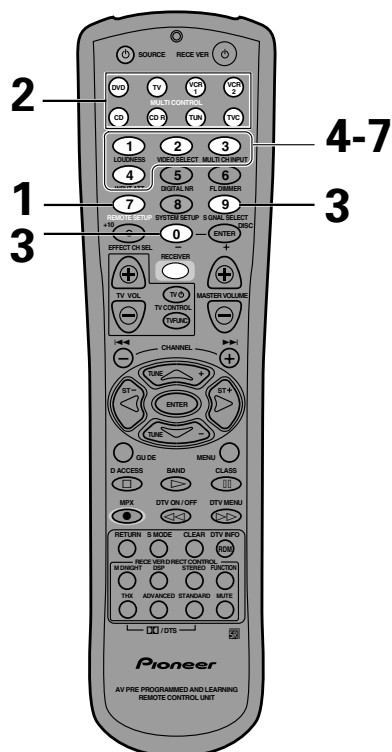

To check which preset code is associated with a Multi Control button:

### 1 Press REMOTE SETUP and hold for three seconds.

The LED on the remote will blink twice.

### 2 Press the MULTI CONTROL button you want to check the preset code for.

### 3 Press 9, 9, then 0.

Each preset code consists of four digits, for example 1329. Each digit will be represented by a series of blinks on the remote's LED—3 blinks to represent the digit "3", etc.

### 4 Press 1.

The blinking LED indicates the left-most digit of the preset code ("1" in the example above).

### 5 Press 2.

The blinking LED indicates the next digit of the preset code ("3" in the example above).

### 6 Press 3.

The blinking LED indicates the next digit of the preset code ("2" in the example above).

### 7 Press 4.

The blinking LED indicates the right-most digit of the preset code ("9" in the example above).

## Clearing One of the Remote Control Settings

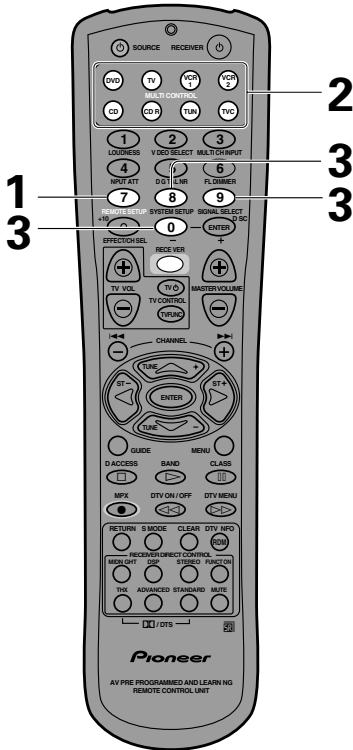

This method clears one of the buttons you have programmed and restores the factory installed preset to that button.

**1 Press REMOTE SETUP and hold for three seconds.**

The LED will blink twice.

**2 Press the MULTI CONTROL button relating to the button to be cleared.**

**3 Press 9, 8, then 0.**

**4 Press the button to be cleared.**

**5 Press the button to be cleared once more.**

The LED blinks twice to indicate the button has been cleared.

## Clearing All the Remote Control Settings

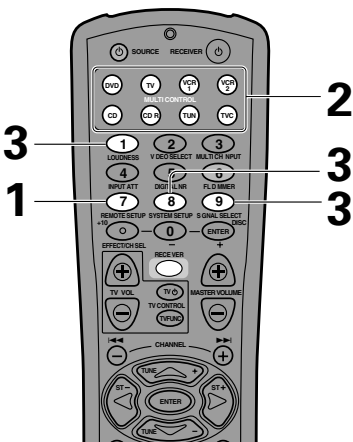

Clears all presents, all learned functions and restores the factory presets.

**1 Press REMOTE SETUP and hold for three seconds.**

The LED will blink twice.

**2 Press the MULTI CONTROL button .**

**3 Press 9, 8, then 1.**

The LED blinks in sets of two twice (thus four times) to indicate the button has been cleared.

# CD/CD-R/MD/VCR/LD Player Controls



This remote control can control these components after entering the proper codes or teaching the receiver the commands (see p.55-59).

**Use MULTI CONTROL buttons to put the remote control in the stated mode.**

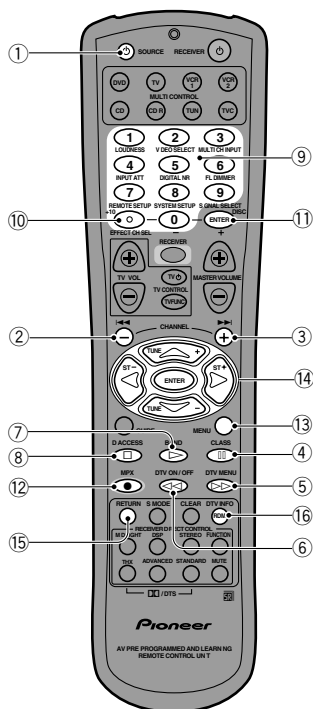

### ① SOURCE

Press to switch the CD, CD-R or MD player between **STANDBY** and **ON**.



Press to return to the start of the current track. Repeated presses skips to the start of previous tracks. When controlling a VCR, use this button to go back channels (channel -).



Press to advance to the start of the next track. Repeated presses skips to the start of following tracks. When controlling a VCR, use this button to go forward channels (channel +).



Press to pause playback.



Hold down for fast forward playback.



Hold down for fast reverse playback.



Press to start playback.



Press to stop playback (on some models, pressing this when the disc is already stopped will cause the disc tray to open).

### ⑨ Number Buttons

Used to directly access tracks on a program source.

### ⑩ +10 Button

Use this button to select tracks higher than 10. Press this button and the remaining number to get the track (+10 Button + 3= track 13).

### ⑪ ENTER (DISC) Button

For a multiple CD player use this button to choose the disc. On an MD player use it ejects the disc, on a VCR it switches between the VCR tuner and the TV tuner. On an LD it changes sides of the LD.

### ⑫ ● MPX Button

Use to start recording. To prevent accidental recording, this button must be pressed twice to take effect (the second press must be within 10 seconds of the first). For a LD player use this button to change the LD between sides A and B.

### ⑬ MENU

Press to advance to the start of the next track. Repeated presses skips to the start of following tracks.

### ⑭ ◀▶ ▲▼ & ENTER buttons

These buttons can be used play or stop (etc.) many components and also to navigate DVD menus/options. Specifically:

◀ to rewind or reverse program source

▶ to fast forward program source

▲ to pause program source

▼ to stop program source

**ENTER** to play program source

### ⑮ RETURN Button

Use to program the playback order of tracks on a disc.

### ⑯ DTV INFO (RDM) Button

For a CD player use this button to choose random mode.

For a LD player use this button to change the LD between analog and digital.

For a VCR use this button to switch the VCR between its tuner (for watching videos) and the TV.

## Cassette Deck Controls



This remote control can control these components after entering the proper codes or teaching the receiver the commands (see p.55-59).

**Use MULTI CONTROL buttons to put the remote control in the stated mode.**

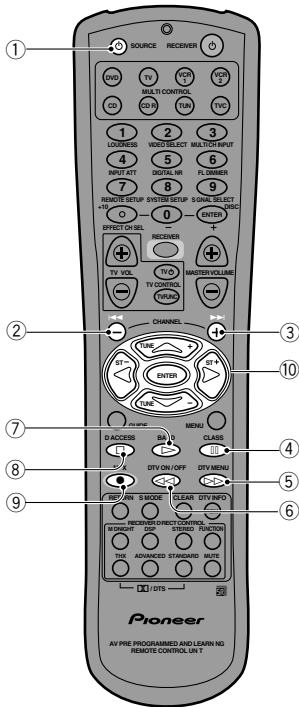

① **SOURCE**

Press to switch the cassette deck between **STANDBY** and **ON** (not possible on all models).

② **REVERSE**

Use to play the reverse side of the tape on a reversible deck.

③ **FORWARD**

Use to play the forward side of the tape on a reversible deck.

④ **PAUSE**

Press to pause playback or recording.

⑤ **FAST FORWARD**

Press to fast forward the tape. Pressing during playback starts forward search.

⑥ **REWIND**

Press to rewind the tape. Pressing during playback starts reverse search.

⑦ **PLAY**

Press to start playback.

⑧ **STOP**

Press to stop playback.

⑨ **MPX Button**

Use to start recording. To prevent accidental recording, this button must be pressed twice to take effect (the second press must be within 10 seconds of the first).

⑩ **THESE CONTROLS CAN BE USED FOR DECK ONE OF A DUAL TAPE DECK**

▲ : Press to pause the tape.

▼ : Press to stop the tape.

**ENTER** : Press to start playback

◀ : Press to rewind the tape.

▶ : Press fast forward the tape

## DVD/DVR Player Controls



This remote control can control this component after entering the proper codes or teaching the receiver the commands (see p.55-59).

**Use MULTI CONTROL buttons to put the remote control in the stated mode.**

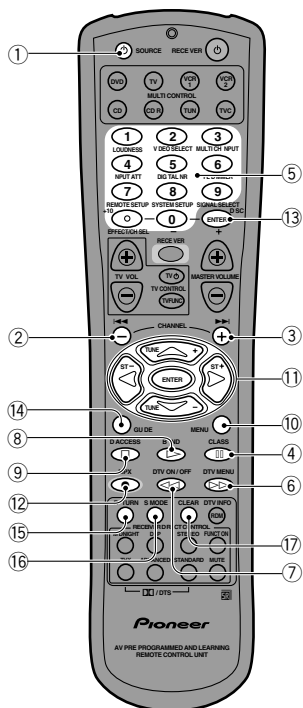

① **SOURCE**

Press to switch the DVD/LD player between STANDBY and ON.

② **⏮**

Press to return to the start of the current chapter (track). Repeated presses skips to the start of previous tracks. When controlling a DVR, use this button to go back channels (channel +).

③ **⏭**

Press to advance to the start of the next chapter (track). Repeated presses skips to the start of following tracks. When controlling a DVR, use this button to go forward channels (channel +).

④ **⏸**

Press to pause playback (on some models this will freeze-frame the picture).

⑤ **Number buttons**

Use the number buttons to navigate the on-screen display.

The **ENTER** button is used as a **SETUP** button for the DVD players internal menus. The **+10** button is used to select tracks higher than 10.

⑥ **⏩**

Hold down for fast forward playback.

⑦ **⏪**

Hold down for fast reverse playback.

⑧ **▶**

Press to start playback (on some models, pressing this when the disc tray is empty will cause the disc tray to open).

⑨ **■**

Press to stop playback (on some models, pressing this when the disc is already stopped will cause the disc tray to open).

⑩ **MENU**

Displays menus concerning the current DVD or DVR you are using.

⑪ **USE THESE BUTTONS TO NAVIGATE DVD MENUS**

▲ : up

▼ : down

**ENTER**: enter the command selected

◀ : left

▶ : right

⑫ **● MPX Button**

Use to start recording. To prevent accidental recording, this button must be pressed twice to take effect (the second press must be within 10 seconds of the first).

⑬ **ENTER**

Use to display the lead trailer on a DVD.

⑭ **GUIDE**

Press to call up the menu programmed on the DVD.

⑮ **RETURN**

Press to return to the beginning of the current chapter (track). Press repeatedly to return to the beginning of previous chapters (tracks)..

⑯ **S.MODE**

Use to select the screen mode.

⑰ **CLEAR**

This button clears the on-screen display (OSD) for the DVD menu.

## DTV Controls



This remote control can control these components after entering the proper codes or teaching the receiver the commands (see p.55-59).

**Use MULTI CONTROL buttons to put the remote control in the stated mode.**

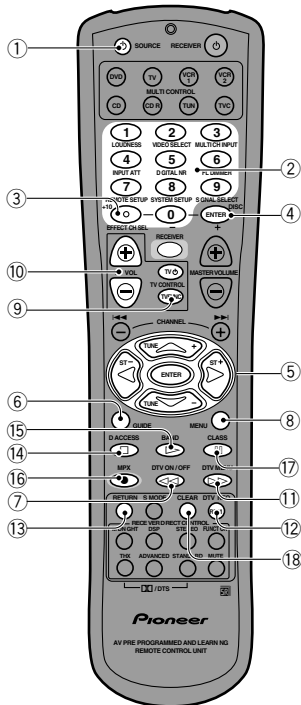

- ① **POWER SOURCE**  
Press to switch the TV or CATV between **STANDBY** and **ON**.
- ② **Number buttons**  
Use to select a specific TV channel.
- ③ **(+10) button**  
Use to add a decimal point when selecting a specific TV channel.
- ④ **ENTER (DISC) button**  
Use to enter a channel.
- ⑤ **▲/▼/◀/▶/ENTER**  
Press to select or adjust and navigate items on the menu screen.  
**ENTER** : Use to bring up the DTV menus.
- ⑥ **GUIDE**  
Use as the GUIDE button for navigating .
- ⑦ **DTV ON/OFF**  
Press to switch the DTV on or off.
- ⑧ **MENU**  
Use to select different menus from the DTV functions.  
**THESE FOUR BUTTONS ARE DEDICATED TV CONTROL BUTTONS FOR ANY TYPE OF TV SETUP.**
- ⑨ **TV FUNC. (TV only)**  
Press to switch the TV input (not possible with some models).
- ⑩ **TV VOL +/-**  
Use to adjust the TV volume.
- ⑪ **DTV MENU**  
Use to select different menus from the DTV functions.
- ⑫ **DTV INFO**  
Use to get INFO on the DTV program.
- ⑬ **RETURN**  
Use to return channels.
- ⑭ **■**  
Use to choose the BLUE commands on a DTV menu.
- ⑮ **▶**  
Use to choose the GREEN commands on a DTV menu.
- ⑯ **●**  
Use to choose the YELLOW commands on a DTV menu.
- ⑰ **II**  
Use to choose the RED commands on a DTV menu.
- ⑱ **CLEAR**  
Press to clear the DTV menu.

# Cable TV/Satellite TV/TV Controls



This remote control can control these components after entering the proper codes or teaching the receiver the commands (see p.55-59).

**Use MULTI CONTROL buttons to put the remote control in the stated mode.**

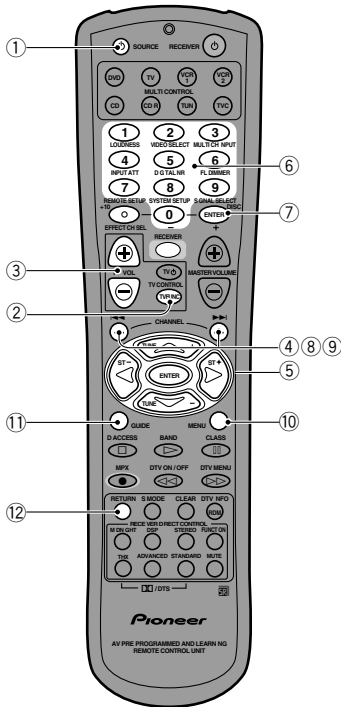

① **SOURCE**

Press to switch the TV or CATV between **STANDBY** and **ON**.

② **TV FUNC (TV only)**

Press to switch the TV input. (Not possible with all models. If it doesn't work with the preset code, use the learning feature.)

③ **TV VOL +/-**

Use to adjust the TV volume.

④ **CHANNEL +/-**

Use to select channels.

⑤ **▲/▼/◀/▶/ENTER**

Press to select or adjust and navigate items on the menu screen.

⑥ **Number buttons**

Use to select a specific TV channel.

⑦ **ENTER (DISC) button**

Use to enter a channel.

⑧ **◀◀**

Use to move to lower numbered channels

⑨ **▶▶**

Use to move to higher numbered channels

⑩ **MENU**

Use to select the menu screen.

⑪ **GUIDE**

Use to bring up the GUIDE on a satellite TV.

⑫ **RETURN**

Use to return channels.



# Using Other Functions

## Function Rename

Use the FUNCTION RENAME capability to rename the functions, like DVD/LD, CD, etc., in the display. You might want to do this in order to personalize the display on the receiver or if your components are different than the names preset in the receiver (for example if you connect a video camera to the VIDEO jacks on the front of the receiver). Follow the display on the receiver to carry out this task.

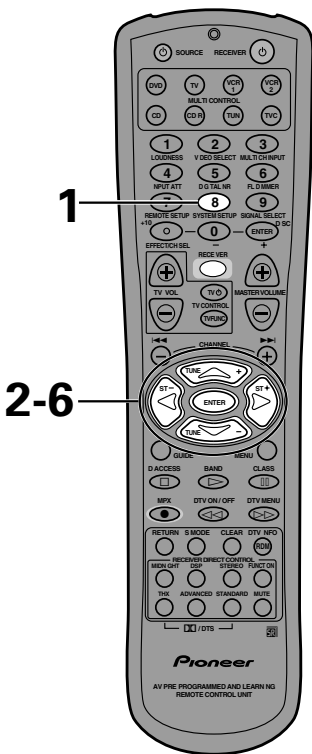
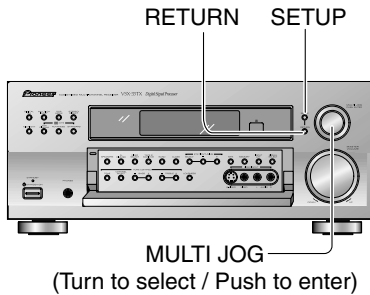

- 1 Press the **SETUP** button (**SYSTEM SETUP** button on the remote control).

Asian Set ---

- 2 Use the **MULTI JOG** dial (**▲/▼** buttons on the remote control) to select **FUNCTION RENAME**.

Rename ---

- 3 Press the **MULTI JOG** dial (**ENTER** on the remote control).

- 4 Use the **MULTI JOG** dial (**▲/▼** buttons) to select the function that you want to rename.

VIDEO ---

- 5 Press the **MULTI JOG** dial (press **ENTER**).

- 6 Use the **MULTI JOG** dial (**▲/▼** buttons) to choose the first character.

The **MULTI JOG** dial scrolls through the letters, numbers and symbols you can input.

Here are all the possible characters you can input:

ABCDEFGHIJKLMNOPQRSTUVWXYZ  
abcdefghijklmnopqrstuvwxyz  
0123456789  
!"#%&'()\*+,-./:;<=>?\_

## Using Other Functions

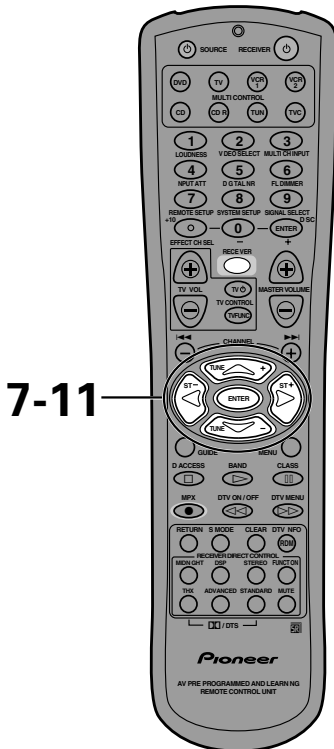
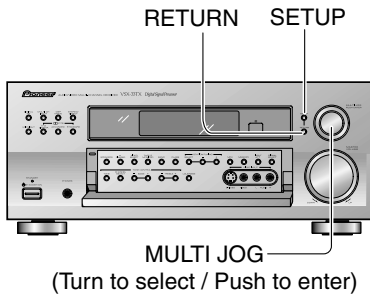

### 7 Press the MULTI JOG dial (press ENTER).

That character appears on the screen and the cursor automatically moves to the next space.



After ten characters have been entered, the character input mode is exited.

### 8 Repeat steps 4 to 7, spell out the function name you want to rename.



- You can include spaces, hyphens, most punctuation marks, other symbols and capital or lowercase letters in the name.
- When you want to change a function name, input the new function name using the same procedure.
- If you make a mistake you can use the RETURN button (◀ button) to go back a step.
- You can press the SETUP button (SYSTEM SETUP button on the remote control) to exit the process altogether. If you've input characters however, these will be entered.

### 9 Use the MULTI JOG dial (▲/▼ buttons) to select "Rename End".



### 10 Press the MULTI JOG dial (press ENTER). "Setup End" will appear in the display.



### 11 Press the MULTI JOG dial again (press ENTER).

You will return to the previous mode the receiver was in.

## Recording from Audio Components

The following explanations show you how to record an analog or digital audio signal. Note that your analog components cannot record a player that is only connected digitally (and vice-versa). If you want to record from a digital component to an analog one (for example, a tape deck), or vice-versa, the digital component it must be connected via analog jacks and you need to set the SIGNAL SELECT switch to ANALOG. To make exact digital copies (of digital sources like CDs) both the source component and the recorder must be connected with digital connections. See p.12 for more on analog audio connections and p.13 for digital audio connections.



The receiver's volume, channel level, balance, TONE, DIGITAL NR, MIDNIGHT, LOUDNESS and surround effects have no effect on the recorded signal and the MULTI CHANNEL IN cannot be recorded. In some cases, digital recordings have copy guard protections and making a digital copy is not possible. In this case you can only copy them in an analog manner.

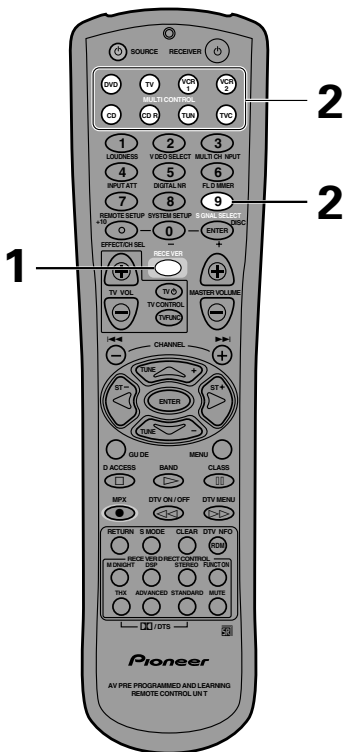

### 1 Press RECEIVER.

This switches the remote to the receiver control mode.

### 2 Select the source component. Set SIGNAL SELECT according to the source component's signal (ANALOG or DIGITAL).

Press the SIGNAL SELECT button on the remote control (or use the button on the front panel) and choose ANALOG.

### 3 Start recording with a recorder.

### 4 Playback the source to be recorded.

## Record monitor (TAPE 2 MONITOR)

If you connect a cassette deck with a record monitor function to the TAPE 2 MONITOR jacks, you can listen to the sound of an analog recording as it is being recorded.

Press TAPE 2 MONITOR to switch between the sound of the recording (TAPE 2 indicator on) and the sound of the source component (TAPE 2 indicator off).

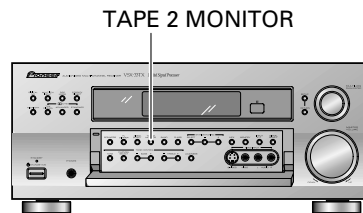

## Recording from Digital Audio Components

The following explanations show you how to record digital audio. Using this method you can make exact digital copies of sources like CDs or MDs. The only drawback is that you cannot switch between various recorders at the touch of a button like you can with analog recordings (see the previous page). If you look on the back of the receiver you will find one digital out jack which are marked PCM/DIG/DTS. If you connect this to the optical input on a digital recorder (currently these include MD, DAT, and CD-R), you can make direct digital recordings with this unit. Of course, the digital components you want to record, all need to be connected to the receiver with digital inputs as well. See p.13 if you have not made these connections.



The receiver's volume, channel level, tone (BASS, TREBLE, and LOUDNESS), and surround effects have no effect on the recorded signal.

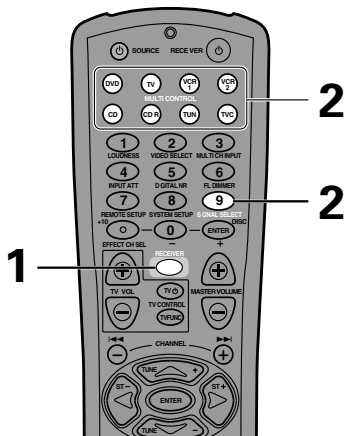

### 1 Press RECEIVER.

This switches the remote to the receiver control mode.

### 2 Prepare the source you want to record and put the receiver in that function. Set SIGNAL SELECT to DIGITAL.

Press the SIGNAL SELECT button on the remote control (or use the button on the front panel) and choose DIGITAL.

### 3 Start recording with a CD-R or MD (etc.).

### 4 Play back the source to be recorded.



In some cases, digital recordings have copy guard protections on them and making a digital copy is not possible. It is still possible to copy these digital sources if you have hooked the components up with analog connections (in this case, the copies will not be exact digital reproductions). Refer to the previous page in this case.

## Recording from Video Components

The following operations show you how to record audio and video to the video tape recorder connected to the VCR 1, VCR 2 or DVR jacks. Note that all signals coming out of these jacks will be analog and it is not possible to record Dolby Digital/DTS soundtracks.



The receiver's volume, channel level, balance, TONE, DIGITAL NR, MIDNIGHT, LOUDNESS and surround effects have no effect on the recorded signal.

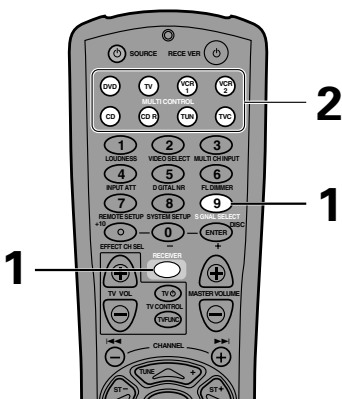

### 1 First, decide the component you'd like to record and put the receiver in that function. Set the SIGNAL SELECT to analog.

Press the SIGNAL SELECT button on the remote control (or use the button on the front panel) and choose analog.

Recording DIGITAL signals is not possible.

### 2 Start recording with VCR 1 or VCR 2 (etc.).

### 3 Playback the source to be recorded.

## Direct Function

The direct function is a useful feature which allows you keep the receiver in one function (for example, CD) while putting the remote control in a different function. This could let you, for example, use the remote control to set up and listen to a CD on the receiver and then use the remote control to rewind a tape in your VCR while you continue to listen to your CD player.

When the DIRECT function is ON any MULTI CONTROL button you press will change the function of both the receiver and the remote control. When you turn the DIRECT function OFF, you can operate the remote control without affecting the receiver. Thus you could switch the remote control the VCR and operate that component while the receiver plays a different component.

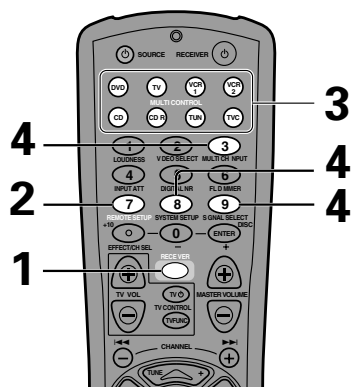

To set a MULTI-CONTROL button to DIRECT OFF:

### 1 Press RECEIVER.

This switches the remote to the receiver control mode.

### 2 Press REMOTE SETUP and hold for three seconds.

The LED will blink twice.

### 3 Press MULTI CONTROL button which you want to set to OFF.

### 4 Press 9, 8, then 3.

The LED blinks twice to indicate the button has been cleared.

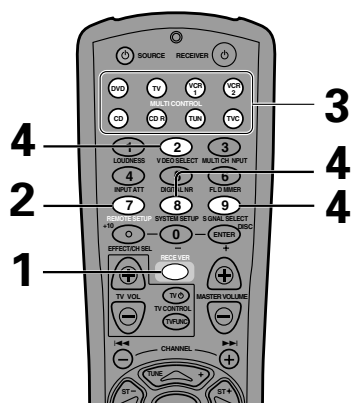

To set a MULTI-CONTROL button to DIRECT ON:

### 1 Press RECEIVER.

This switches the remote to the receiver control mode.

### 2 Press REMOTE SETUP and hold for three seconds.

The LED will blink twice.

### 3 Press MULTI CONTROL button which you want to set to ON.

### 4 Press 9, 8, then 2.

The LED blinks twice to indicate the button has been cleared.



TV CONT doesn't have this feature and thus can't use the DIRECT FUNCTION.

## Using Other Functions

### Video Select

This function allows you to listen to one sound source while you watch a different video source on your TV. The sound source is set in the normal fashion as is explained on p.42. You then alter the video input with the VIDEO SELECT button.

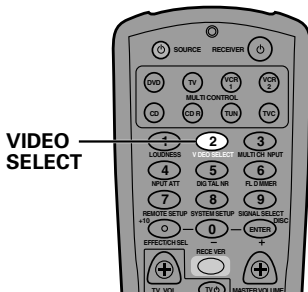
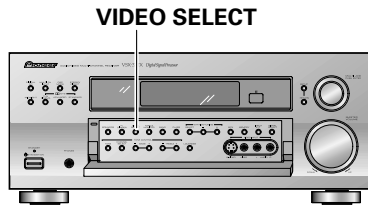

**Press the VIDEO SELECT button on the front panel to cycle through the different possible video inputs.**

The first press shows the video input you are currently using. After that pressing VIDEO SELECT cycles through the possibilities in the following order:

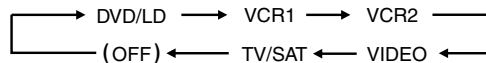

The OFF setting means that no video signal is output.

After choosing a video input the display on the receiver will show that input for about 5 seconds and then revert to showing the sound mode the receiver is in.

**The VIDEO SELECT remains set to the input you chose until you change the audio input.**

If you change audio functions the receiver will reset itself to make the video and audio inputs correspond.

Also, if you switch the power of the receiver OFF when you turn it back on the video and audio inputs will reset so that they correspond.

### Changing the Display

You can change the display on the front panel between the function and the sound mode by pressing the MULTI JOG dial (see #16 on p.23).

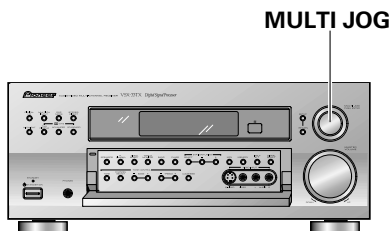

**Press the MULTI JOG dial on the front panel to move between the function (DVD/LD, CD, etc.) display and the sound mode display.**

The display will remain on the setting you choose. If you turn the MULTI JOG dial to select a new function the function is displayed.

# Techno Tidbits & Problem-solving

## Dolby Digital



Dolby Digital is a compression format which records the sound of 6 channels of the theater surround system (Dolby Digital) on the movie film digital track. Of the 6 channels, the sub woofer channel is intended for bass only, and because the frequency range is smaller than the main channel, it is expressed as 5.1 channel.

Dolby Digital is the name of the Dolby surround multi-channel digital system that was developed after the Dolby Surround System and Dolby Pro Logic Surround System.

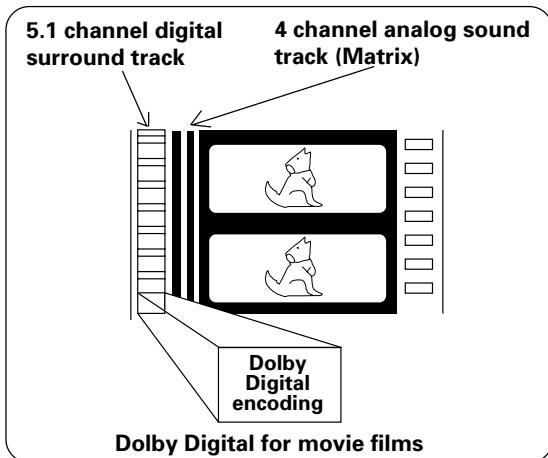

The number of movies made using Dolby Digital since 1992 has exceeded 300 and continues to increase. For compact disc players and laser disc digital sounds, 16 bits are used to sample the original analog audio waveform and sampling is carried out 44,100 times every second. However because an enormous amount of recording signal data is required for the multi channel system with this method, Dolby Digital is used to compress the data.

In reproducing audio signals, the smaller the bit number used, the lower the sound quality. With Dolby Digital, drop in auditory sound quality is prevented by using masking technology and digital filtering technology based on the human auditory characteristics.

## Laser disc format

Laser discs are now available on the market in large numbers. This means that the recording of different format audio signals on the laser disc raises the important question of compatibility with existing laser discs. Dolby Digital tracks on laser discs record signals using the space of one analog audio channel so it will maintain compatibility with existing discs and players.

As shown in the following figure, the digital audio sounds of Dolby Digital discs can be played back as currently done. Analog sounds are played back by using the other channel without the Dolby Digital signals for monaural audio signals.

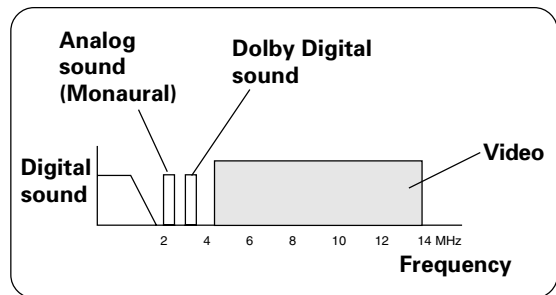

## DTS



DTS has been adopted as a sound recording format in the latest movie theaters since the release of "JURASSIC PARK" in 1993, and has a good reputation for high quality sound and dynamic surround effects.

In this system, 6 channels of digital sound are recorded on CD-ROM, rather than on the film. DTS adopts a simultaneous playback format. With a low rate of compression of sound signals and a high rate of transmittance, a higher sound quality format is produced. Also, unlike the process of recording digital sounds on film directly, the only components required are a CD-ROM player as might be used with a personal computer and a DTS processor, and therefore less investment is required than with other formats. For this reason, the format is being introduced in more and more movie theaters, and is being adopted in home movie software (DVD, LD) and music software (5.1 channel CD).

# THX



THX is a Lucasfilm, Ltd. program dedicated to maximum accuracy in movie presentation. Movie sound tracks are recorded in large movie dubbing stages using movie theater equipment. For a sound track to be presented accurately in your home, special technologies are required. In your home the room is much smaller and has a bright sound, the speakers are very different and there are only six of them, plus, you sit much closer to each one of those speakers. Because of these differences we often miss the power and emotion that thrills us in a good movie. Now Pioneer and THX have teamed up to bring the full glory of accurate cinema sound to the comfort and convenience of your home.

**Re-Equalization™** : In a theater the room is very large and dead sounding, you sit a long way back from the speakers and the speakers themselves are very specialized. Because a sound track recorded in this dead sounding space when it is played at home it sounds overbright. THX Re-Equalization adjusts for this difference in a very precise way.

**Adaptive Decorrelation™** : When a sound track sends mono sound to the surround speakers it often seems to be coming from one side instead of from all around you as it would in a theater. Adaptive Decorrelation helps to correct this inaccuracy.

**Timbre Matching™** : When recording a sound track it is very important that the surround sounds move smoothly and seamlessly around the theater. It is very distracting when sounds seem to jump from speaker to speaker. Timbre Matching helps to smooth the movement of the surround sounds even though you are using only two speakers.

**Bass Peak Level Manager™** : Some Dolby Digital sound tracks can produce bass peaks that are undesirable in a home theater environment. The Bass Peak Level Manager allows you to set the maximum peak levels appropriate to your system. (Set this function according to the **Bass Level** instructions on page 37.)

**Loudspeaker Position Time Synchronization™** : This feature allows you to adjust for the difference in the distance from each individual loudspeaker to the listening position. Doing this ensures that all the speakers operate in precise synchronization improving the seamless nature of the soundfield. (Set this function according to the **Channel Delay** instructions on p.33.)



## Preset Code List

Device	Manufacturer	Manufacturer Code	Device	Manufacturer	Manufacturer Code	Device	Manufacturer	Manufacturer Code	
DVD	Denon	0490	TV	Alaron	0179	TV	Emerson	0019,0038,0039	
	GE	0522		Allegro	0720,0774		0154,0177,0178		
	Harman/Kardon	0582		Ambassador	0177		0179,0180,0236		
	JVC	0558,0623		Ameroca Action	0180		0282,0463,0623		
	Kenwood	0534		Ampro	0751		0624		
	Magnavox	0503		Amstrad	0412		Fiderity	0412,0512	
	Marantz	0539		Anam National	0161,0250,0425		Fisher	0154	
	Mitsubishi	0521		Anam	0004,0009,0068		Fortress	0093	
	Onkyo	0503,0627			0161,0180,0250		Fujitsu	0179	
	Optimus	0571			0425		Futuretech	0180	
	Panasonic	0490,0632		Audiovox	0092,0180,0451		Funai	0171,0179,0180	
	Philips	0503,0539			0623			0264	
	Proscan	0522		Baur	0010,0512		GE	0021,0047,0051	
	RCA	0522		Baysonic	0180			0093,0178,0282	
	Samsung	0573		Belcor	0019			0451,1147,1347	
	Sharp	0630		Bell & Howell	0016,0154		Gibraltar	0017,0019,0030	
	Sony	0533		Beon	0418		GoldStar	0001,0002,0019	
	Technics	0490		Bradford	0180			0030,0037,0039	
	Theta Digital	0571		Brinkmann	0418			0056,0178	
	Toshiba	0503		Brackwood	0019		Goodmans	0035	
	Yamaha	0490,0545		Broksonic	0236,0463		Gradiente	0053,0056,0170	
	Zenith	0503,0591		CCE	0037		Granada	0108,0339	
	Pioneer	0525,0571,0632		CGE	0418		Grundig	0037	
		0631(DVD-RW)		CXC	0180		Grunpy	0179,0180	
	LD	Akai		0598	Candle		0030,0056	Hallmark	0178
		Amoisonic		0475	Carnivale		0030	Harley Davidson	0179
		BBK		0624	Carver		0054,0170	Harman/Kardon	0054
Denon		0059	Celebrity	0000	Harvard	0068,0180			
Disco Vision		0023	Cineral	0092,0451	Harwood	0412			
Funai		0584	Citzen	0030,0039,0056	HCM	0412,0418			
Hitachi		0023		0060,0092	Hitachi	0016,0038,0056			
Hong Deng		0542	Concerto	0056		0145			
Idall		0595	Contec	0180	Imperial	0418			
Kebao		0581	Craig	0161,0180	Infinity	0054			
Mitsubishi		0059	Crosley	0054	Innova	0037			
NAD		0059	Crown	0039,0180,0339	Interfunk	0512			
Optimus		0059		0418	Inteq	0017			
Panasonic		0496	Curtis Mathes	0016,0030,0039	IR	0010,0035,0108			
Philips		0475		0047,0051,0054		0512			
Rowa		0541		0056,0060,0093	ITT	0339			
SMC		0596		0145,0154,1166	JBL	0054			
Sega		0023		0451,0466,1147	JCB	0000			
Sharp		0597		1347	JVC	0036,0053,0069			
Shinco		0540	Daewoo	0019,0039,0066		0160,0418			
Sony		0193,0201,0583		0092,0154,0451	KEC	0180			
		0589		0623,0624	KTV	0030,0039,0180			
Super		0581	Dansai	0035	Kenwood	0019,0030			
Toshiba		0599	Daytron	0019	Kyoshu	0412			
Pioneer		0023,0059,0463	Denon	0145	LG	0056			
		0572	Dumont	0017,0019	Loewe	0512			
TV		AOC	0019,0030	Dwin	0720,0774	LXI	0047,0054,0154		
		Admiral	0093,0463	ECE	0037		0156,0178		
		Aiko	0092	Electroband	0000	Logik	0016		
		Akai	0030,0035	Envision	0030	Luxman	0056		
		Akura	0412	Etron	0009,0646	M Electronic	0512		

## Techno Tidbits & Problem-solving

Device	Manufacturer	Manufacturer Code	Device	Manufacturer	Manufacturer Code	Device	Manufacturer	Manufacturer Code			
TV	Matsui	0035	TV	RCA	0019,0038,0047	TV	Teknika	0016,0019,0039			
	MGA	0019,0030,0150					0051,0090,0093			0054,0056,0060	
		0178					1047,1147,1247			0092,0150,0179	
	MTC	0019,0030,0056					1347,1447			0180	
		0060,0512			Radio Shack		0019,0030,0039		Thorn	0035,0512	
	Magnavox	0030,0036,0054					0047,0056,0154		Toshiba	0035,0036,0060	
		0179					0165,0178,0180			0154,0156	
	Majestic	0016			Realistic		0019,0030,0039		Totevision	0039	
	Manesth	0035					0056,0154,0165		Uher	0418	
	Marantz	0030,0037,0054					0178,0180		Universum	0010,0418,0512	
	Matsushita	0250			Royal Lux		0412		Vector Research	0030	
	Megatron	0145,0178			Roadstar		0418		Victor	0036,0053,0160	
	Minutz	0021			Runco		0017,0030,0603			0250	
	Memorex	0016,0056,0150			SKY		0037		Vidikron	0054	
		0154,0178,0250			SSS		0019,0180		Vidtech	0019,0036,0178	
		0463			Samsung		0019,0030,0037		Voxson	0418	
	Minoka	0412					0056,0060,0090		Waltham	0418	
	Midland	0017,0039,0047					0178		Wards	0016,0019,0021	
		0051			Sampo		0030,0039			0030,0054,0056	
	Mitsubishi	0019,0093,0150			Samsux		0039			0165,0178,0179	
		0178,0108,0512			Sansei		0451				
	Motorola	0093			Sansui		0463		White		
	Multitech	0180			Sanyo		0108,0154,0208		Westinghouse	0463,0623,0624	
	NAD	0156,1166,0178					0339		Yamaha	0019,0030	
	NTC	0092			Scimitsu		0019		Yoko	0339	
	NEC	0019,0030,0036			Scotch		0178		Zenor	039	
		0056,0170			Scott		0019,0178,0179		Zenith	0016,0017,0092	
	Neckermann	0418					0180,0236			0463,0624	
	Netsat	0037			Sinudyne		0010		Pioneer	0038,1166,0172	
	Nikkai	0035			Semivox		0180			0679	
	Nikko	0030,0092,0178			Semp		0156				
	Nokia	0339			Sears		0047,0054,0056		CATV	ABC	1003,1008,1011
	Onwa	0180					0154,0156,0171				1014
	Optimus	0154,1166,0250					0178,0179		Bell & Howell		1014
	Optonica	0093,0165			SEI		0010		Contec		1019
	Orion	0179,0236,0463			Sentra		0035		Daehan		1778
	Osaki	0412			Sharp		0039,0093,0165		Daeryung		1008
	Otto Versand	0010,0512			Shogun		0019		Everquest		1015
	Palladium	0418			Signature		0016		Gemini		1015
	Panasonic	0051,0161,0250			Sky-Worth		0037		GoldStar		1144,1838
	Penny	0002,0019,0021			Sonitron		0339		General		1011,1276,1476
		0030,0039,0047			Sony		0000,0010		Instrument		1810
		0051,0056,0060			Soundesign		0178,0179,0180		Hitachi		1011
	0156,0178,1347		Soundwave	0418		Jasco		1015			
Philco	0019,0030,0054		Squareview	0171		Jerrold		1003,1011,1012			
	0145,0418,0463		Starlite	0180				1014,1015,1276			
Philips	0037,0054		Supreme	0000				1476,1810			
Pilot	0019,0030,0039		Sylvania	0030,0054		LG Alps		1779			
Portland	0019,0039,0092		Symphonic	0171		Memorex		1000			
Prism	0051		TMK	0056,0177,0178		Now		1776			
Proscan	0047		Tandy	0093		Oak		1019			
Protech	0418		Technics	0051,0250		Pacific		1678			
Proton	0178,0466		Technal Ace	0179		Panasonic		1000,1107			
Pulsar	0017,0019		Techwood	0051,0056		Paragon		1000			
Quasar	0051,0165,0250		Telefunken	0056		Pulsar		1000			
Quelle	0010,0512					Quasar		1000			

## Techno Tidbits & Problem-solving

Device	Manufacturer	Manufacturer Code	Device	Manufacturer	Manufacturer Code	Device	Manufacturer	Manufacturer Code
CATV	Radio Shack	1015	SAT	Radio Shack	1869	CD/ CD-R/ MD	MCS	0029
	Rembrandt	1011		Sanyo	1493		QED	0157
	Runco	1000		Sharp	1494		Quasar	0029
	Samsung	1144,1702		Sony	1275,1639,1661		RCA	0053,0179,0305
	Scientific Atlanta	1008,1477,1877		Star Choice	1869		Realistic	0179,0180,0420
	Seawoo	1780		Tae Kwang	1733		Rotel	0157,0420
	Signal	1015		Toshiba	1486,1790		SAE	0157
	Signature	1011		Uniden	1722,1724		Sansui	0157,0305
	Starcom	1003,1015		VTech	1321		Sanyo	0179,0349
	Stargate	1015		Victor	1492,1505,1506		Scott	0305
	Starquest	1015		Zenith	1856		Sears	0305
	Taihan	1778		Pioneer	1662,1329		Sharp	0037,0180,0861
	Tocom	1012		1010 (DTV,SAT)	Sherwood		0114,0180	
	Tongkook	1777,1840	CD/ CD-R/ MD	Aiwa	0124,0157		Sony	0000,0185,0490
	Toshiba	1000		Anam	0362		Soundesign	0145
	Tusa	1015		Burmester	0420		Tascam	0420
	Zenith	1000,1525		California Audio Labs	0029,0303		Teac	0174,0180,0393
	Pioneer	1023,1144,1260 1533		Carver	0157,0179,0437		Technics	0029,0303
				DKK	0000			
				Denon	0003,0358,0873		Toshiba	0481
		Dynamic Bass		0179	Victor	0072		
		Emerson		0305	Wards	0053,0157		
		Eroica		0562,0563	Yamaha	0036,0187		
		Fantasia		0525	Yorx	0461		
		Fisher		0174,0179	Pioneer	0032,0244,0305		
		Garrard		0393,0420		0468,0551		
		Genexxa		0032,0305		1062 (CD-R)		
		GoldStar		0383,0525		1063 (MD)		
		Harman/Kardon		0157,0173		1087		
		Hitachi		0032				
		Inkel		0114,0180,0437	TAPE ADC	1171		
		JVC	0072	Aiwa	1029,1197,1223			
		Kenwood	0028,0037,0190 0626,0681,0826	Akai	1189			
				Anam	1364			
		Krell	0157	Carver	1029,1261			
		LXI	0305	Denon	1076			
		Linn	0157	Dual	1383			
		Luxman	0266	Dynamic Bass	1261			
		MCS	0029	Eroica	1418			
		MTC	0420	Fisher	1261			
		Magnavox	0157,0305	Garrard	1375			
		Marantz	0029,0157,0180	GoldStar	1375			
		Mission	0157	Harman/Kardon	1029,1182			
		NSM	0157	Inkel	1070			
		Nikko	0174,0362,0525	JVC	1244,1273			
		Onkyo	0101,0381,0868	Kenwood	1070			
		Optimus	0000,0032,0037 0145,0179,0305 0420,0437,0468	Kyocera	1171			
				Lotte	1339			
				Luxman	1266			
				Magnavox	1029			
		Panasonic	0029,0303	Marantz	1029			
		Parasound	0420	Nakamichi	1218			
		Philips	0157,0626	Nikko	1364			
SAT	AlphaStar	1772						
	Chaparral	1216						
	Dae Young	1735						
	Daeryung	1396						
	Echostar	1396,1775						
	Expressvu	1775						
	General Instrument	1361,1627,1869						
	HTS	1775						
	Hitachi	1489,1819						
	Hughes Network Systems	1749						
	Hung Chang	1732						
	JVC	1492,1505,1506 1775						
	Jerrold	1361,1627						
	JiWon	1364						
	Kabil	1737						
	Magnavox	1722,1724						
	Marantz	1200						
	Memorex	1724						
	Mitsubishi	1491						
	NEC	1496,1499,1507 1508						
Next Level	1869							
Panasonic	1340,1500,1701							
Philips	1200,1722,1724							
Primestar	1361,1627							
RCA	1143,1392,1566 1855							

## Techno Tidbits & Problem-solving

Device	Manufacturer	Manufacturer Code	Device	Manufacturer	Manufacturer Code	Device	Manufacturer	Manufacturer Code	
TAPE	Olympus	1266	VCR	Denon	0042	VCR	Memorex	0000,0035,0037	
	Onkyo	1135,1282		Dynatech	0000				0039,0046,0047
	Optimus	1027,1220		Electrohome	0037				0048,0104,0209
	Panasonic	1229		Electrophonic	0037				0240,0307,1037
	Philips	1029		Emerex	0032				1162,1262
	RCA	1261		Emerson	0000,0002,0037			Minolta	0042
	Renaissance	1413			0043,0121,0184			Motorola	0035,0048
	Samsung	1391			0208,0209,0278			Multitech	0000,0072
	Sansui	1029			0479,0561			NAD	0058
	Sanyo	1261		Fisher	0047,0104			NEC	0038,0040,0041
	Sonic	1375		Fuji	0035				0067,0104
	Sony	1170,1243,1291		Funai	0000			National	0226
	Teac	1391		GE	0035,0048,0060			Nikko	0037
	Technics	1229			0240			Nikon	0034
	Victor	1244,1273		Garrard	0000			Noblex	0240
	Wards	1027		General	0052			Olympus	0035,0226
	Yamaha	1094,1097		Go Video	0432,0526			Optimus	0037,0048,0058
	Pioneer	1027,1099,1101		GoldStar	0037,0038,0225				0104,0162,0432
					0480				1048,1062,1162
					0000,0008				1262
VCR	Admiral	0048,0209	Gradiente	0000,0008		Orion	0002,0184,0209		
	Adventura	0000	HI-Q	0047			0479		
	Aiko	0278	Harley Davidson	0000		Panasonic	0035,0162,0225		
	Aiwa	0000,0037,0307	Harman/Kardon	0038,0081			0226,0227,1062		
	Akai	0041,0106,0281	Harwood	0072			1162,1262		
		0315	Headquarter	0046		Penney	0035,0037,0038		
	America Action	0278	Hitachi	0000,0041,0042			0040,0042,0240		
	American High	0035		0166.,0235		Pentax	0042		
	Anam	0037,0162,0226	Hughes Network	0042		Philco	0035,0209,0479		
		0240,0278,0553	Systems			Phillips	0035,0081		
		0579	JVC	0008,0041,0067		Pilot	0037		
	Anam National	0162,0226,1162	Jensen	0041		Portland	0020		
	Asha	0240	KEC	0037,0278		Profitronic	0240		
	Audiovox	0037	KLH	0072		Proscan	0060		
	Beaumarck	0240	Kenwood	0038,0041,0067		Protec	0072		
	Boll & Howell	0104	Kodak	0035,0037		Pulsar	0039		
	Blaupunkt	0226	LG	0480		Quarter	0046		
	Broksonic	0002,0121,0184	LXI	0037		Quartz	0046		
		0209,0479	Lloyd's	0000,0208		Quasar	0035,0162,1162		
			Logik	0072		RCA	0035,0042,0048		
	CCE	0072,0278	MEI	0035			0060,0106,0240		
	Calix	0037	MGA	0043,0240		Radio Shack	0000,1037		
	Canon	0035	MGN Technology	0240		Radix	0037		
	Capehart	0020	MTC	0000,0240		Randex	0037		
	Carver	0081	Magnasonic	0278		Realistic	0000,0035,0037		
	Cineral	0278	Magnavox	0000,0035,0039			0046,0047,0048		
	Citizen	0037,0278		0081			0104		
	Craig	0037,0047,0072	Magnin	0240		Ricoh	0034		
		0240,0271	Marantz	0035,0081		Runco	0039		
			Marta	0037		STS	0042		
	Curtis Mathes	0035,0041,0060	Matsushita	0035,0162,0227		Samsung	0045,0240,0426		
		0162	Mitsubishi	0043,0048,0067			0432		
	Colt	0072		0173		Sanky	0039,0048		
	Cybernex	0240	Marantz	0035,0081		Sansui	0000,0041,0067		
	Daewoo	0020,0045,0046	Marta	0037			0209,0271,0479		
		0278,0561	Matsushita	0035,0162,0227		Sanyo	0046,0047,0104		
	Daytron	0020	Mitsubishi	0043,0048,0067			0240		
	Denon	0042		0173		Scott	0043,0045,0121		
							0184		

Device	Manufacturer	Manufacturer Code	Device	Manufacturer	Manufacturer Code
VCR	Sears	0000,0035,0037	RECEIVERS	ADC	0531
		0042,0046,0047		Aiwa	0121,0301,1089
	0104			1405	
	Semp	0045		Akai	0115
	Sharp	0048,0363		Anam	0112,0609
	Shintom	0072		Capetronic	0531
	Shogun	0240		Carver	1089,1189
	Singer	0072		Curtis Mathes	0080
	Sony	0000,0032,0034		Daewoo	0407
		0035		Denon	1104,1160
	Sylvania	0000,0035,0043		Dual	0512
		0081		Eroica	0051
	Symphonic	0000		Fantasia	0466
	TMK	0208,0240		GP Audio	0423
	Tatung	0041		Garrard	0407,0440,0463
	Teac	0000,0041		GoldStar	0112
	Technics	0035,0162		Harman/Kardon	0110,0891
	Teknika	0000,0035,0037		Inkel	0502,0512
		0052		JBL	0110
	Thomas	0000		JVC	0074
	Toshiba	0043,0045		Kenwood	0186,1027,1313
	Totevision	0037,0240			1569
	Unitech	0240		Lotte	0466,0506
	Vector	0045		Luxman	0267
	Vector Research	0038,0040		MCS	0039
	Victor	0008,0041,0067		Magnavox	0391,0531,1089
	Video Concepts	0040,0045			1189
	Videosonic	0240		Marantz	0039,1089,1189
	Wards	0000,0035,0042		McIntosh	0258
		0047,0048,0060		McSilver	0466
	0072,0081,0240	Nikko	0407,0466,0609		
White		Onkyo	0135,0380		
Westinghouse	0209,0278	Optimus	0080,0186,0440		
XR-1000	0000,0035,0072		0531,0670,1023		
Yamaha	0038	Panasonic	0039,1518		
Zenith	0000,0034,0039	Philips	0391,0891,1089		
	0209,0479		1189		
Pioneer	0058,0067,0168	Pioneer	0014,0080,0150		
DAT	Carver	0158		0289,0531,0630	
	Denon	0031		1023	
	Harman/Kardon	0158	Quasar	0039	
	Magnavox	0158	RCA	0054,0531	
	Marantz	0158	Renaissance	0564	
	Philips	0158	Samsung	0112	
	Sony	0093	Sansui	1089	
	Pioneer	0019	Sharp	0186	
			Sherwood	0502	
			Sony	1058,1158,1258	
		Soundesign	0670		
		Sunfire	1313		
		Tae Kwang	0440		
		Teac	0112,0463		
		Technics	0039,1308,1309		
			1518		
		Thorens	1189		
		Victor	0074		
		Wards	0014,0054,0080		
		Yamaha	0176,0186		

## Troubleshooting

Incorrect operations are often mistaken for trouble and malfunctions. If you think that there is something wrong with this component, check the points below. Sometimes the trouble may lie in another component. Investigate the other components and electrical appliances being used. If the trouble cannot be rectified even after exercising the checks listed below, ask your nearest PIONEER authorized service center or your dealer to carry out repair work.

<b>Symptom</b>	<b>Cause</b>	<b>Remedy</b>
The power does not turn ON.	<ul style="list-style-type: none"> <li>• The power plug is disconnected.</li> <li>• The protection circuit may have been activated.</li> </ul>	<ul style="list-style-type: none"> <li>• Connect the power plug to the wall outlet.</li> <li>• Plug in again. If it still doesn't work call a service center.</li> </ul>
The unit does not respond when the buttons are pressed.	<ul style="list-style-type: none"> <li>• Static electricity caused by dry air.</li> </ul>	<ul style="list-style-type: none"> <li>• Disconnect the power plug from the outlet, and insert again.</li> </ul>
No sound is output when a function is selected.	<ul style="list-style-type: none"> <li>• Improper connections.</li> <li>• Sound is muted.</li> <li>• The volume is turned down.</li> <li>• The TAPE 2 MONITOR is ON.</li> <li>• Speakers are turned OFF.</li> <li>• DIGITAL/ANALOG switch is set incorrectly.</li> <li>• The digital inputs are assigned incorrectly, or not at all.</li> </ul>	<ul style="list-style-type: none"> <li>• Make sure the component is connected correctly (see p. 12-21).</li> <li>• Press MUTE on the remote control.</li> <li>• Adjust MASTER VOLUME.</li> <li>• Press the TAPE 2 MONITOR button.</li> <li>• Press SPEAKERS (A/B) to select the speakers you connected.</li> <li>• Set SIGNAL SELECT (see p.44).</li> <li>• Set the digital input settings correctly (see p.29).</li> </ul>
No image is output when a function is selected.	<ul style="list-style-type: none"> <li>• Improper connections.</li> <li>• The input source is not properly selected.</li> </ul>	<ul style="list-style-type: none"> <li>• Make sure the component is connected correctly (see p.12-21).</li> <li>• Press the correct function button.</li> </ul>
Considerable noise in radio broadcasts.	<ul style="list-style-type: none"> <li>• Incorrect frequency.</li> <li>• The antenna is not connected.</li> <li>• <b>RF</b> and/or digital cables are near the antenna terminals and wires.</li> </ul>	<ul style="list-style-type: none"> <li>• Tune in the correct frequency.</li> <li>• Connect the antenna (see p.18).</li> <li>• Route <b>RF</b> and digital cables away from the antenna terminals and wires.</li> </ul>
	<p><b>FM broadcasts</b></p> <ul style="list-style-type: none"> <li>• The FM antenna is not fully extended or is poorly positioned.</li> <li>• Weak radio signals.</li> </ul>	<ul style="list-style-type: none"> <li>• Fully extend the FM wire antenna, position for best reception, and secure to a wall.</li> <li>• Connect an outdoor FM antenna (see p.18).</li> </ul>
	<p><b>AM broadcasts</b></p> <ul style="list-style-type: none"> <li>• The AM antenna is poorly positioned.</li> <li>• Weak radio signals.</li> <li>• Interference caused by other equipment (fluorescent lamp, motor, etc.).</li> </ul>	<ul style="list-style-type: none"> <li>• Adjust the direction and position for best reception.</li> <li>• Connect an additional internal or external AM antenna (see p.18).</li> <li>• Turn off the equipment causing the noise or move it away from the receiver.</li> <li>• Place the antenna farther away from the equipment causing the noise.</li> </ul>
Broadcast stations cannot be selected automatically.	<ul style="list-style-type: none"> <li>• Weak radio signals.</li> </ul>	<ul style="list-style-type: none"> <li>• Connect an outdoor antenna (see p.18).</li> </ul>
Subwoofer output is very low.	<ul style="list-style-type: none"> <li>• Settings route signal away from sub woofer.</li> </ul>	<ul style="list-style-type: none"> <li>• To get more signal to the subwoofer set it to PLUS or choose SMALL for the FRONT speakers (see p.31-32).</li> </ul>
When playing an LD the SIGNAL SELECT is on DIGITAL but there is still no sound.	<ul style="list-style-type: none"> <li>• The LD is not a Dolby Digital compatible disc.</li> </ul>	<ul style="list-style-type: none"> <li>• Set the SIGNAL SELECT to analog (make sure your LD player is hooked up with analog connections in addition to digital and <b>RF</b> (with RF demodulator connections, see p.14).</li> </ul>
When playing a Dolby Digital / DTS source the 5.1 Channel indicator doesn't light.	<ul style="list-style-type: none"> <li>• The Dolby Digital / DTS source is not 5 channels.</li> </ul>	<ul style="list-style-type: none"> <li>• There is no problem with the receiver but if you want 5 channel sound you must play a 5 channel source.</li> </ul>

## Techno Tidbits & Problem-solving

<b>Symptom</b>	<b>Cause</b>	<b>Remedy</b>
No sound from surround or center speakers.	<ul style="list-style-type: none"> <li>• Speaker settings are incorrect.</li> <li>• The rear and/or center levels are turned down.</li> <li>• The surround and/or center speakers are disconnected.</li> </ul>	<ul style="list-style-type: none"> <li>• See "Speaker Setting" on p.31-32 to check the speaker settings.</li> <li>• See "Channel Level" p.34-35 to check the speaker levels.</li> <li>• Connect the speakers (see p.19).</li> </ul>
Sound is produced from some components, but not from digital components.	<ul style="list-style-type: none"> <li>• SIGNAL SELECT is set incorrectly.</li> <li>• The digital inputs are assigned incorrectly, or not at all.</li> </ul>	<ul style="list-style-type: none"> <li>• Set SIGNAL SELECT to "AUTO" or according to the type of connections made (see p. 44).</li> <li>• Set the digital input settings correctly (see p.29).</li> </ul>
No sound is output or a noise is output when software with DTS is played back.	<ul style="list-style-type: none"> <li>• SIGNAL SELECT is set to "ANALOG".</li> <li>• A DVD player not compatible with DTS is used, or the setting of the DVD player is incorrect.</li> <li>• The digital output level has been turned down on a CD player or other component equipped with digital output level adjustment capability. (The DTS signal has been altered by the player, and cannot be read.)</li> <li>• The speakers are turned OFF.</li> </ul>	<ul style="list-style-type: none"> <li>• Make digital connections (see p.13) and set SIGNAL SELECT to "AUTO" (see p.44).</li> <li>• Refer to the instruction manual supplied with the DVD player.</li> <li>• Set the digital volume level of the player to full, or to the neutral position.</li> <li>• Turn the speakers ON.</li> </ul>
The sound is output intermittently when software with DTS is played back.	<ul style="list-style-type: none"> <li>• Disc being played back has a huge amount of information on it.</li> </ul>	<ul style="list-style-type: none"> <li>• Use the STANDARD mode to get the best results (see p.42).</li> </ul>
When a search is performed by a DTS compatible CD player during playback, noise is output.	<ul style="list-style-type: none"> <li>• The search function performed by the player interferes with the reading of digital information.</li> </ul>	<ul style="list-style-type: none"> <li>• This is not a malfunction, but be sure to turn the volume down to prevent the output of loud noise from your speakers.</li> </ul>
Cannot be remote controlled.	<ul style="list-style-type: none"> <li>• The remote control batteries have worn out.</li> <li>• Too far away or bad angle of operation.</li> <li>• There is an obstacle between the receiver and the remote control.</li> <li>• Strong light such as fluorescent light is shining onto the unit's remote control signal light-receiving window.</li> <li>• A cord is connected to the CONTROL IN terminal on this unit.</li> </ul>	<ul style="list-style-type: none"> <li>• Replace the batteries (see p.10).</li> <li>• Operate within 23ft (7 m), 30° of the remote sensor on the front panel (see p.11).</li> <li>• Remove the obstacle or operate from another position.</li> <li>• Avoid exposing the remote sensor on the front panel to direct light.</li> <li>• Connect cord to the correct jack.</li> </ul>
The display is dark.	<ul style="list-style-type: none"> <li>• The FL DIMMER button is pushed.</li> </ul>	<ul style="list-style-type: none"> <li>• Press FL DIMMER on the front panel repeatedly to return to the default setting (see p.49).</li> </ul>
The OVER indicator is constantly lit.	<ul style="list-style-type: none"> <li>• If you are using an analog source, the signal is too strong.</li> </ul>	<ul style="list-style-type: none"> <li>• Press the INPUT ATT button (see p.24).</li> </ul>
When playing a Dolby Digital / DTS format LD there is noise audible on the soundtrack.	<ul style="list-style-type: none"> <li>• If you are using a digital source, there is too much information for the receiver to handle.</li> <li>• The SIGNAL SELECT is on ANALOG.</li> </ul>	<ul style="list-style-type: none"> <li>• For /DTS sources put the receiver in STANDARD mode (see p.42).</li> <li>• Set the SIGNAL SELECT to DIGITAL.</li> </ul>

## Techno Tidbits & Problem-solving

Symptom	Cause	Remedy
You can't get DIGITAL to come up when using the SIGNAL SELECT button.	<ul style="list-style-type: none"> <li>Either the digital connections or the DIGITAL IN SELECT choices are incorrect.</li> <li>The TAPE2 MONITOR mode is ON.</li> </ul>	<ul style="list-style-type: none"> <li>Make sure the digital connections and the DIGITAL IN SELECT choices are done correctly.</li> <li>Press the TAPE2 MONITOR button so it goes into the OFF setting.</li> </ul>
The Dolby Digital / DTS indicator doesn't light up even when playing a Dolby Digital / DTS source.	<ul style="list-style-type: none"> <li>The player is paused or stopped.</li> <li>There is a mistake in the player settings for audio output.</li> <li>Although it's a Dolby Digital / DTS source there is a possibility the present track is not Dolby Digital / DTS.</li> </ul>	<ul style="list-style-type: none"> <li>Play the source.</li> <li>Fix the audio settings (check the manual that came with your DVD player).</li> <li>There is no problem. The indicator won't light when the track is not a Dolby Digital / DTS track.</li> </ul>

### If the unit does not operate normally due to external effects such as static electricity

Disconnect the power plug from the outlet and insert again to return to normal operating conditions.

### STATION CALL button fill in sheet

It's a good idea to make a note of your preset stations.

CLASS A	Station No.	*1	*2	*3	*4	*5
	Station Name					
	Frequency					
	Station No.	*6	*7	*8	*9	*0
	Station Name					
	Frequency					
CLASS B	Station No.	*1	*2	*3	*4	*5
	Station Name					
	Frequency					
	Station No.	*6	*7	*8	*9	*0
	Station Name					
	Frequency					
CLASS C	Station No.	*1	*2	*3	*4	*5
	Station Name					
	Frequency					
	Station No.	*6	*7	*8	*9	*0
	Station Name					
	Frequency					



# Specifications

## Amplifier Section

**Continuous average power output of 80 watts\* per channel, min., at 8 ohms, from 20 Hz to 20,000 Hz with no more than 0.09%\*\* total harmonic distortion (front).**

### Continuous Power Output

Front ..... 80 W + 80 W (20Hz-20 kHz, 0.09 %, 8 Ω)  
 Center ..... 80 W (20Hz-20 kHz, 0.09 %, 8 Ω)  
 Rear ..... 80 W + 80 W (20Hz-20 kHz, 0.09 %, 8 Ω)

### Input (Sensitivity/Impedance)

VCR 1/DVR, VCR 2, DVD/LD, TV/SAT, VIDEO, CD,  
 CD-R/TAPE 1/MD, TAPE 2 ..... 335 mV/47 kΩ

### Frequency Response

VCR 1/DVR, VCR 2, DVD/LD, TV/SAT, VIDEO, CD, <sup>+0</sup>  
 CD-R/TAPE 1/MD, TAPE 2 .... 5 Hz to 100,000 Hz <sub>-3</sub>dB  
 VCR 1/DVR REC, VCR 2 REC, CD-R/TAPE 1/MD REC,  
 TAPE 2 REC ..... 335 mV/2.2 kΩ

### Tone Control

BASS ..... ± 6 dB (100 Hz)  
 TREBLE ..... ± 6 dB (10 kHz)  
 LOUDNESS ..... +10 dB (100 Hz/10 kHz)

### Signal-to-Noise Ratio (IHF, short circuited, A network)

VCR 1/DVR, VCR 2, DVD/LD, TV/SAT, VIDEO, CD,  
 CD-R/TAPE 1/MD, TAPE 2 ..... 101 dB  
 MULTI CH IN ..... 101 dB

### Signal-to-Noise Ratio [EIA, at 1 W (1 kHz)]

VCR 1/DVR, VCR 2, DVD/LD, TV/SAT, VIDEO, CD,  
 CD-R/TAPE 1/MD, TAPE 2 ..... 83 dB

\* Measured pursuant to the Federal Trade Commission's Trade Regulation rule on Power Output Claims for Amplifiers.

\*\* Measured by Audio Spectrum Analyzer.

## VIDEO Section (S jack)

### Input (Sensitivity/Impedance)

VCR 1/DVR, VCR 2, VIDEO, DVD/LD, TV/SAT  
 Luminance signal (Y) ..... 1 V<sub>p-p</sub>/75 Ω  
 Chrominance signal (C) ..... 0.286 V<sub>p-p</sub>/75 Ω

### Output (Level/Impedance)

VCR 1/DVR, VCR 2, MONITOR OUT  
 Luminance signal (Y) ..... 1 V<sub>p-p</sub>/75 Ω  
 Chrominance signal (C) ..... 0.286 V<sub>p-p</sub>/75 Ω

### Frequency Response

VCR 1/DVR, VCR 2, VIDEO, DVD/LD, TV/SAT  
 Luminance signal (Y) ..... 5 Hz to 10 MHz <sup>+0</sup><sub>-3</sub>dB

### Signal-to-Noise Ratio

Luminance signal (Y) ..... 65 dB

## VIDEO Section (Composite)

### Input (Sensitivity/Impedance)

VCR 1/DVR, VCR 2, VIDEO, DVD/LD,  
 TV/SAT ..... 1 V<sub>p-p</sub>/75 Ω

### Output (Level/Impedance)

VCR 1/DVR, VCR 2, MONITOR OUT ..... 1 V<sub>p-p</sub>/75 Ω

### Frequency Response

VCR 1/DVR, VCR 2, TV/SAT, DVD/LD  
 VIDEO→MONITOR OUT, ..... 5 Hz to 10 MHz <sup>+0</sup><sub>-3</sub>dB

Signal-to-Noise Ratio ..... 65 dB

## FM Tuner Section

Frequency Range ..... 87.5 MHz to 108 MHz  
 Usable Sensitivity ..... Mono: 13.2 dBf, IHF (1.3 μV/75 Ω)  
 50 dB Quieting Sensitivity ..... Mono: 20.2 dBf  
 Stereo: 38.6 dBf  
 Signal-to-Noise Ratio ..... Mono: 73 dB (at 85 dBf)  
 Stereo: 70 dB (at 85 dBf)  
 Distortion ..... Stereo: 0.5 % (1 kHz)  
 Alternate Channel Selectivity ..... 60 dB (400 kHz)  
 Stereo Separation ..... 40 dB (1 kHz)  
 Frequency Response ..... 30 Hz to 15 kHz (± 1) dB  
 Antenna Input ..... 75 Ω unbalanced

## AM Tuner Section

Frequency Range ..... 530 kHz to 1,700 kHz  
 Sensitivity (IHF, Loop antenna) ..... 350 μV/m  
 Selectivity ..... 25 dB  
 Signal-to-Noise Ratio ..... 50 dB  
 Antenna ..... Loop antenna

## Miscellaneous

Power Requirements ..... AC 120 V, 60 Hz  
 Power Consumption ..... 400 W, 550 VA  
 Power Consumption in Standby mode ..... 1.0 W  
 AC Outlet SWITCHED (x2) ..... Total 100 W (0.8 A) MAX  
 Dimensions ..... 420 (W) × 173 (H) × 463 (D) mm  
 (16-9/16 (W) × 6-13/16 (H) × 18-1/4 (D) in.)  
 Weight (without package) ..... 14.6 kg (32 lb 3 oz)

## Furnished Parts

FM wire Antenna ..... 1  
 AM loop Antenna ..... 1  
 "AA" IEC LR6 batteries ..... 2  
 Remote Control Unit ..... 1  
 Operating Instructions ..... 1

### NOTE:

Specifications and the design are subject to possible modifications without notice, due to improvements.



### *Dear Customer:*

Selecting fine audio equipment such as the unit you've just purchased is only the start of your musical enjoyment. Now it's time to consider how you can maximize the fun and excitement your equipment offers. This manufacturer and the Electronic Industries Association's Consumer Electronics Group want you to get the most out of your equipment by playing it at a safe level. One that lets the sound come through loud and clear without annoying blaring or distortion-and, most importantly, without affecting your sensitive hearing.

Sound can be deceiving. Over time your hearing "comfort level" adapts to higher volumes of sound. So what sounds "normal" can actually be loud and harmful to your hearing. Guard against this by setting your equipment at a safe level BEFORE your hearing adapts.

#### **To establish a safe level:**

- Start your volume control at a low setting.
- Slowly increase the sound until you can hear it comfortably and clearly, and without distortion.

#### **Once you have established a comfortable sound level:**

- Set the dial and leave it there.

Taking a minute to do this now will help to prevent hearing damage or loss in the future. After all, we want you listening for a lifetime.

## We Want You Listening For A Lifetime

Used wisely, your new sound equipment will provide a lifetime of fun and enjoyment. Since hearing damage from loud noise is often undetectable until it is too late, this manufacturer and the Electronic Industries Association's Consumer Electronics Group recommend you avoid prolonged exposure to excessive noise. This list of sound levels is included for your protection.

#### **Decibel**

<u>Level</u>	<u>Example</u>
30	Quiet library, soft whispers
40	Living room, refrigerator, bedroom away from traffic
50	Light traffic, normal conversation, quiet office
60	Air conditioner at 20 feet, sewing machine
70	Vacuum cleaner, hair dryer, noisy restaurant
80	Average city traffic, garbage disposals, alarm clock at two feet.

#### **THE FOLLOWING NOISES CAN BE DANGEROUS UNDER CONSTANT EXPOSURE**

90	Subway, motorcycle, truck traffic, lawn mower
100	Garbage truck, chain saw, pneumatic drill
120	Rock band concert in front of speakers, thunderclap
140	Gunshot blast, jet plane
180	Rocket launching pad

Information courtesy of the Deafness Research Foundation.



### **Power cord CAUTION!**

Handle the power cord by the plug. Do not pull out the plug by tugging the cord and never touch the power cord when your hands are wet as this could cause a short circuit or electric shock. Do not place the unit, a piece of furniture, etc., on the power cord, or pinch the cord. Never make a knot in the cord or tie it with other cords. The power cords should be routed such that they are not likely to be stepped on. A damaged power cord can cause a fire or give you an electrical shock. Check the power cord once in a while. When you find it damaged, ask your nearest PIONEER authorized service center or your dealer for a replacement.

### **Maintenance of External Surfaces**

- Use a polishing cloth or dry cloth to wipe off dust and dirt.
- When the surfaces are dirty, wipe with a soft cloth dipped in some neutral cleanser diluted five or six times with water, and wrung out well, and then wipe again with a dry cloth. Do not use furniture wax or cleaners.
- Never use thinners, benzene, insecticide sprays or other chemicals on or near this unit, since these will corrode the surfaces.



Should this product require service in the U.S.A. and you wish to locate the nearest Pioneer Authorized Independent Service Company, or if you wish to purchase replacement parts, operating instructions, service manuals, or accessories, please call the number shown below.

**8 0 0 – 4 2 1 – 1 4 0 4**

Please do not ship your product to Pioneer without first calling the Customer Service Department at the above listed number for assistance.

PIONEER ELECTRONICS SERVICE, INC.  
CUSTOMER SERVICE DEPARTMENT  
P.O. BOX 1760, LONG BEACH,  
CA 90801-1760, U.S.A.

For warranty information please see the Limited Warranty sheet included with your product.

Should this product require service in Canada, please contact a Pioneer Canadian Authorized Dealer to locate the nearest Pioneer Authorized Service Company in Canada. Alternatively, please contact the Customer Service Department at the following address:

Pioneer Electronics of Canada, Inc.  
Customer Service Department  
300 Allstate Parkway, Markham, Ontario L3R  
OP2  
(905) 479-4411  
1-877-283-5901

For warranty information please see the Limited Warranty sheet included with your product.

Si ce produit doit être réparé au Canada, veuillez vous adresser à un distributeur autorisée Pioneer au Canada pour obtenir le nom de la Société de Service Autorisée Pioneer le plus près de chez vous. Ou encore, veuillez vous communiquer avec le Service de Clientèle de Pioneer:

Pioneer électroniques du Canada, Inc.  
Département de service au consommateurs  
300 Allstate Parkway, Markham, Ontario L3R  
OP2  
(905) 479-4411  
1-877-283-5901

Pour obtenir des renseignements sur la garantie, veuillez vous reporter au feuillet sur la Garantie Limitée qui accompagne le produit.

Published by Pioneer Corporation.  
Copyright © 2000 Pioneer Corporation.  
All rights reserved.

**PIONEER CORPORATION** 4-1, Meguro 1-Chome, Meguro-ku, Tokyo 153-8654, Japan  
**PIONEER ELECTRONICS [USA] INC.** P.O. BOX 1540, Long Beach, California 90801-1540, U.S.A.  
**PIONEER ELECTRONICS OF CANADA, INC.** 300 Allstate Parkway, Markham, Ontario L3R OP2, Canada  
**PIONEER EUROPE NV** Haven 1087, Keetberglaan 1, B-9120 Melsele, Belgium TEL: 03/570.05.11  
**PIONEER ELECTRONICS AUSTRALIA PTY. LTD.** 178-184 Boundary Road, Braeside, Victoria 3195, Australia, TEL: [03] 9586-6300  
**PIONEER ELECTRONICS DE MEXICO S.A. DE C.V.** San Lorenzo 1009 3er Piso Desp. 302 Col. Del Valle Mexico D.F. C.P. 03100  
TEL: 5-688-52-90